

**S O M M A R I O / I N H A L T S A N G A B E / S U M M A R Y**

INTRODUZIONE / ÜBER UNS / ABOUT US .....	2
ALFAROMEIO .....	6
AUDI .....	24
AUTOBIANCHI .....	29
BMW.....	30
CITROÉN.....	33
FERRARI.....	35
FIAT.....	38
FORD.....	52
HONDA.....	58
HYUNDAI.....	60
KIA.....	62
LANCIA.....	63
LAND ROVER.....	67
MASERATI.....	67
MAZDA.....	68
MINI.....	69
NISSAN.....	70
OPEL.....	71
PEUGEOT.....	76
PORSCHE.....	83
RENAULT.....	85
ROVER.....	88
SEAT.....	89
SKODA.....	92
SMART.....	93
SUBARU.....	94
SUZUKI.....	95
TOYOTA.....	98
VOLKSWAGEN.....	99
VOLVO.....	107
CONDIZIONI GENERALI DI VENDITA VERKAUFS- UND LIEFERBEDINGUNGEN (AGB) GENERAL SALES CONDITIONS.....	108

## IL SUCCESSO DI UNA GRANDE PASSIONE

Dopo anni di esperienza maturata nel mondo delle marmitte e dei motori, è nel 1980 che Roberto Cavalli riesce a fondare la sua casa di produzione di silenziatori per auto:

### **CSC: COSTRUZIONE SILENZIATORI COLLETTORI**

La lunga esperienza del titolare coadiuvato dalla professionalità di un team specializzato e la collaborazione con i migliori tuner europei, hanno portato la **CSC MARMITTE** ad affermarsi sul mercato europeo ed extra-europeo quale azienda leader nella produzione di impianti di scarico di alta qualità e performance nel settore automotive.

Nuove tecnologie, idee innovative e design all'avanguardia ci permettono di realizzare un prodotto che si distingue per le caratteristiche tecnico estetiche e per le elevate prestazioni.

Materiali altamente selezionati, macchinari a controllo numerico di ultima generazione, professionalità e cura dei dettagli sono la nostra formula vincente. Ogni singolo prodotto è unico e irripetibile in quanto rifinito completamente a mano.

Continue ricerche e analisi di settore portano a studiare soluzioni ottimali e sempre innovative nell'ottica della piena soddisfazione della clientela. **CSC MARMITTE**, costruisce sistemi di scarico completamente adattabili al ricambio originale. Tutti i prodotti vengono provati e testati su banco prova e omologati CE, pertanto rientrano perfettamente nei parametri imposti dalle norme vigenti. **PASSIONE, PROFESSIONALITÀ E COMPETENZA SONO LE BASI CHE HANNO CONSOLIDATO LA PRESENZA DEI NOSTRI PRODOTTI NEL MONDO.**

**CSC MARMITTE**, la qualità di un prodotto artigianale.

## THE SUCCESS OF GREAT PASSION

CSC was born in 1980 thanks to Roberto Cavalli's ability and experience in building special exhaust systems for sport cars. Roberto Cavalli's long experience together with the collaborator's knowledge and the best European tuner's collaboration, have brought CSC to make a name in both European and world wide markets, for designing and producing sport exhaust systems. The integration of advanced technologies, innovative ideas and leading edge design leads to the creation of products with excellent qualities. CSC silencers stand out because of their technical-aesthetic characteristics, high performances and excellent product life. The latest CSC manufacturing equipment, carefully selected materials, experience and great care in the details are our most important characteristic. Every silencer is a unique example because it is an hand made product. Continuous market researches and analysis make the achievement of optimum solutions possible to constantly improve these products, in the light of total customer satisfaction. Even though CSC does not aim itself at the initial system market is construct exhaust systems that are adaptable as original spare parts. The silencers are carefully tested to obtain the respective type approval and therefore satisfy the parameters established by the standards in force. Passion and professional competence are the bases that have consolidated the presence of CSC products in the automotive sector.

## DER ERFOLG EINER GROßEN LEIDENSCHAFT

Nach jahrelanger Erfahrung im Auspuff- und Motorensektor gründet Roberto Cavalli im Jahre 1980 seine eigene Produktionsstätte für Autoschalldämpfer.

### **CSC: Produktion von Schalldämpfern/Krümmern**

Die langjährige Erfahrung des Inhabers, unter Mithilfe eines spezialisierten Profiteams und Zusammenarbeit mit den besten europäischen Tuner, haben CSC Auspuffanlagen dazu gebracht, sich sowohl im europäischen als auch im außer-europäischen Markt zu behaupten und eine führende high-quality und Performance Position im Auspuffsektor anzunehmen. Neue Technologien, innovative Ideen und avantgardistisches Design ermöglichen es uns, ein Produkt herzustellen, das sich durch technische Merkmale, Ästhetik und höhere Leistung heraushebt. Sorgfältige Auswahl der Rohmaterialien, numerisch gesteuerte Maschinen, Professionalität und Liebe zum Detail sind unsere Siegerformel. Jedes Produkt ist einzigartig, da komplett durch Handarbeit vollendet. Durch beständige Suche und Marktforschung erzielen wir optimale Ergebnisse, die unsere Kunden auch vollends zufrieden stellen. Obwohl CSC nicht für den Erst-Auspuffmarkt produziert, ersetzen unsere Anlagen komplett den Originalauspuff. Alle Produkte werden auf unserem Leistungsprüfstand getestet und EG-genehmigt und sind demnach für den öffentlichen Straßenverkehr gesetzlich zugelassen. Leidenschaft, Professionalität und Kompetenz sind die Grundsätze, die unsere Produkte weltweit erfolgreich machen. CSC Auspuffanlagen – ein qualitativ hochwertiges Handwerksprodukt.

## PRODOTTI OMOLOGATI CEE

*Contrassegnati nel catalogo con il simbolo: ●*

Gli impianti di scarico CSC vengono forniti di relativo estratto del certificato originale di omologazione C.E.E. avente validità in tutti gli stati membri della UE; inoltre, l'identificazione numerica impressa su tutti i nostri prodotti consente una libera sostituzione dei dispositivi silenziatori senza alcun obbligo di aggiornamento sulla carta di circolazione.

## EG-BETRIEBSERLAUBNIS

*Im Katalog gekennzeichnet folgendem Symbol: ●*

CSC Auspuffanlagen werden mit einem originalen, EU-weit gültigen Zertifikat geliefert, ebenso wird durch die eingravierte Identifikationsnummer auf unseren Produkten eine problemloser Ersatz zum Originalteil möglich, ohne Nachtragung auf den Fahrzeugpapieren.

## PRODUCTS WITH E.C. APPROVAL CSC

*Indicated in catalogue with following sign: ●*

CSC exhaust systems respect the law parameters, therefore they obtain the E.C. approval. This certificate is valid in the E.C. countries and is delivered together with our silencers. Moreover we impress the code of the E.C. approval on our exhausts, in order to allow the replacement of the original spare parts without the obligation to update the registration book.



## COLLETTORE / FACHERKRÜMER / MANIFOLD



- (A) Flangia testata in acciaio spessore 10/12 mm  
Head flange; 10/12 mm thickness  
Flansch aus Stahl Stärke 10/12 mm
- (B) Attacco per sonda Lambda (non comporta alcuna modifica all'impianto elettronico dell'autovettura)  
Connection for Lambda probe (sensor) (no modifications to the car electronic system are required)  
Anschluss für Lambasonde (keine Änderung an der Fahrzeug-Elektronik erforderlich)
- (C) Staffe di fissaggio in acciaio INOX 1.4301  
1.4301 Stainless Steel fastening brackets  
Halterung aus Edelstahl (1.4301)
- (D) Tubi di scarico in acciaio INOX 1.4301 spessore 1,5 mm  
1.4301 Stainless Steel exhaust pipes - 1.5 mm thickness  
Auspuffrohre aus Edelstahl (1.4301) Stärke 1.5 mm
- (E) Supporto di fissaggio in acciaio INOX 1.4301  
1.4301 Stainless Steel fixing support  
Halterungen aus Edelstahl (1.4301)
- (F) Supporto di fissaggio in acciaio INOX 1.4301  
1.4301 Stainless Steel fixing support  
Halterungen aus Edelstahl (1.4301)

## SISTEMA INTERNO A SCARICO LIBERO / ABSORPTIONSYSTEM / FREE-EXHAUST INNER SYSTEM

- (G) Tubi di scarico in acciaio INOX 1.4301 spessore 1,5 mm  
1.4301 Stainless Steel exhaust pipes - 1.5 mm thickness  
Auspuffrohre aus Edelstahl (1.4301) 1.5 mm
- (H) Tubo forato in acciaio INOX 1.4301 spessore 1,2/1,5 mm  
1.4301 Stainless Steel drilled pipe - 1.2/1.5 mm thickness  
Siebrohr aus Edelstahl (1.4301) Stärke 1.2/1.5 mm
- (I) Lana di vetro a fibra lunga ad alta densità insonorizzante  
Long-stapled glass wool highly soundproofing  
Langfaser Roving-Glaswolle für hohe Schalldämmung



## SISTEMA INTERNO CHE REGOLA LA COMPRESSIONE E DECOMPRESSIONE DEI GAS DI SCARICO

### REGELUNG VON ABGASDRUCK UND GEGENDRUCK

### INNER SYSTEM ADJUSTING COMPRESSION AND DECOMPRESSION OF EXHAUST GASSES

- (M) Camera di compressione e decompressione dei gas di scarico  
Compression and decompression chamber for exhaust gasses  
Druck- und Gegendruckkammer der Abgase



## 6 GTV ( kW 118 )

'81 &gt; '87

① AL08X00D \*



① AL08X00S \*



Ø 45

Ø 45

④ AL080200 ●  
fino al 06/'84

⑤ AL080032 ●



○ 60

○ 60

## 8C ( kW 295 )

⑤ AL71X286 \*



○ 90

○ 90

## 33 1.3 - 1.7ie ( kW 66 - 75 )

04/'83 &gt; 12/'89

## SUD BERLINA 5M SPRINT ( kW 66 - 75 )

'79 &gt; '84

① AL07X000 \*

Collettore / Fächerkrümmer / Manifold 4-2-1



Ø 42,5

④ AL070200 ●



Ø 42,5

⑤ AL220070 ●



○ 70

⑤ AL050032 ●

Ø 42,5



○ 60

## 33 1.3 - 1.5 - 1.7ie ( kW 58 - 77 )

01/'90 &gt;

Ø 42,5

④ AL070200 ●



Ø 42,5

⑤ AL220070 ●



○ 70

① Collettore / Fächerkrümmer / Manifold - Down pipe

④ Centrale / Mittelschalldämpfer / Center silencer - pipe

② Sport metal kat 200 cell

⑤ Posteriore / Endshalldämpfer / Rear silencer - pipe

③ Anteriore / Vorshalldämpfer / Front silencer



Sonda Lambda

## 33 1.7ie 16v BERLINA ( kW 98 ) '90 > '92



## 33 1.7ie 16v Cat '90 > 08/'92

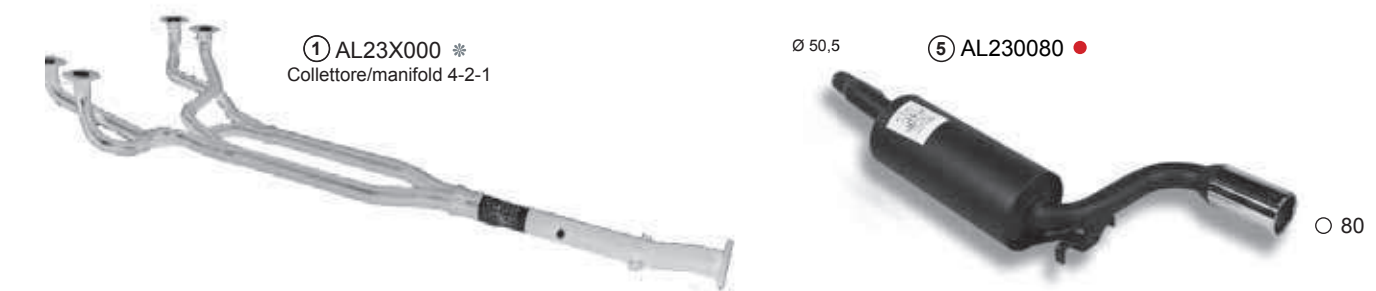

## 75 1.6 - 1.8 - 2.0 (kW 81 - 87 - 94) 05/'85 > '88

## 90 1.8 - 2.0 - 2.0i (kW 87 - 94) 06/'84 > '87



## 75 1.8 ie - 2.0 i.T.S. ( kW 88 - 104) '87 > '92

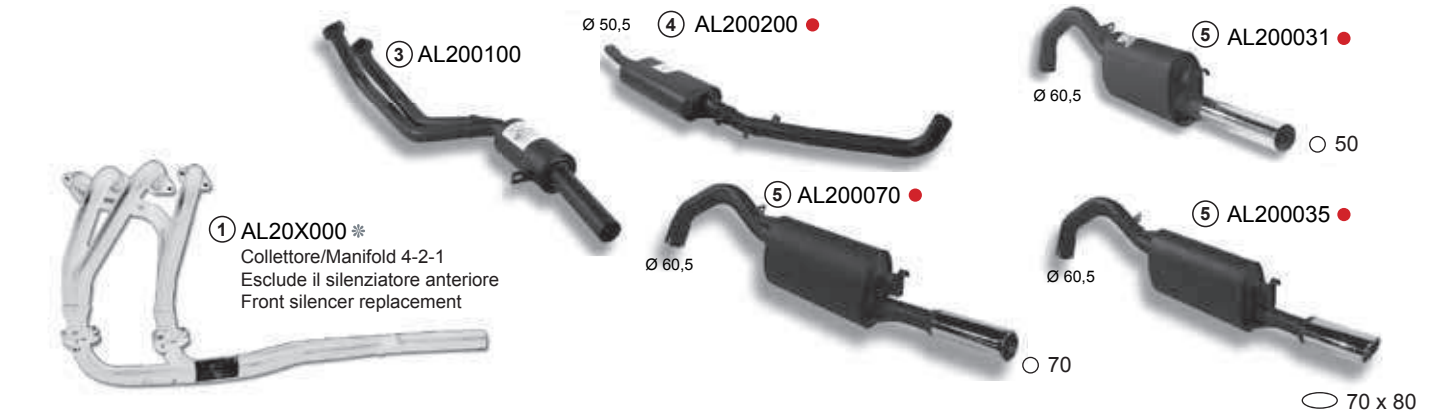

### NOTE

Le marmitte alluminizzate hanno tutti i tubi in acciaio INOX 304  
 Alle rohre der alluminierten schalldampfer bestehen aus Edestahl AISI 304  
 All pipes of the alluminized exhausts are made of stainless steel AISI 304

● Omologato / EG-genehmigt - EU-approved

△ Con modifica paraurti /  
 Änderung der heckschürze / Rear bumper must be cut to fit

\* Acciaio INOX AISI 304 /  
 Edelstahl AISI 304 / Stainless steel AISI 304

**75** 1.6 ie Cat. - 1.8 ie Cat. - 2.0 ie T.S. Cat. (kW 76 - 88 - 103) '87 > '92



**75** 1.8 TURBO (kW 114) '86 > 07/'87



**75** 1.8 i TURBO AMERICA (kW 89) 08/'87 > '91



**75** 2.5 V6 Q ORO - 3.0i V6 Cat. (kW 131 - 136) '88 > '92

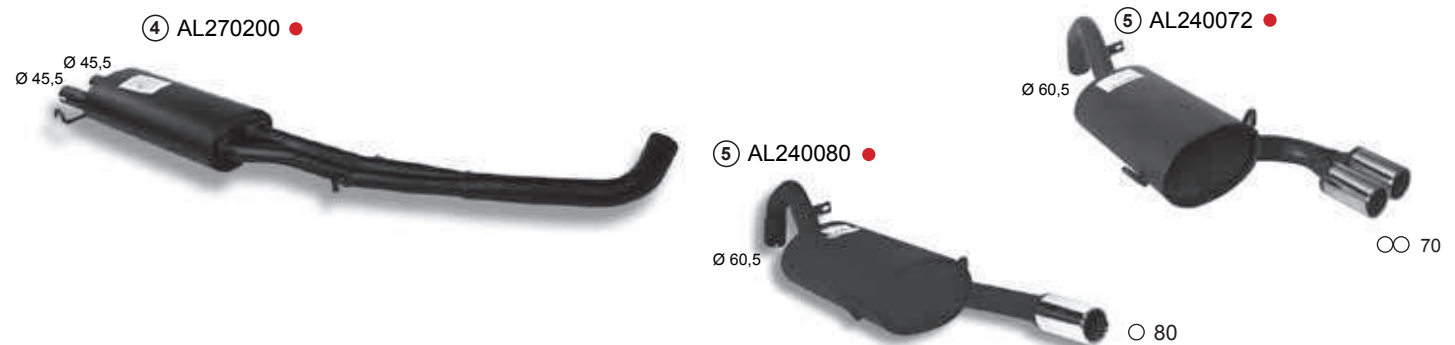

① Collettore / Fächerkrümmer / Manifold - Down pipe

④ Centrale / Mittelschalldämpfer / Center silencer - pipe

② Sport metal kat 200 cell

⑤ Posteriore / Endshalldämpfer / Rear silencer - pipe

③ Anteriore / Vorshalldämpfer / Front silencer



Sonda Lambda

## 75 2.5 V6 Q. VERDE - 3.0 V6 (kW 85 - 102)

'85 > 02/'88

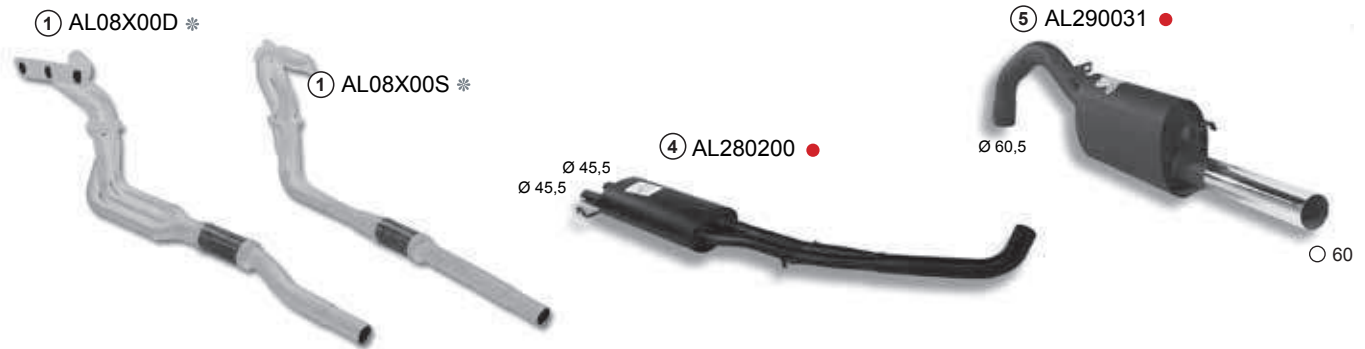

## 75 2.5 V6 - 3.0 i V6 AMERICA (kW 85 - 136)

03/'88 > '92

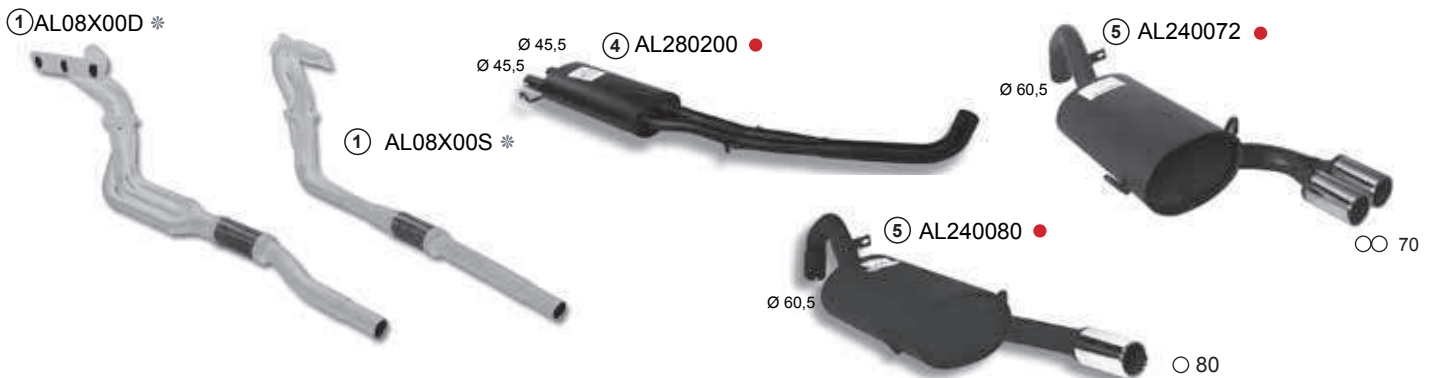

## 145 / 146 1.3 ie - 1.6 ie - 1.7 16v

'94 > '96

KIT COMPLETO - KOMPLETTESS KIT - COMPLETE KIT



## 145 / 146 T.S. 16v 1.4 - 1.6 - 1.8 - 2.0

'97 >

KIT COMPLETO - KOMPLETTESS KIT - COMPLETE KIT

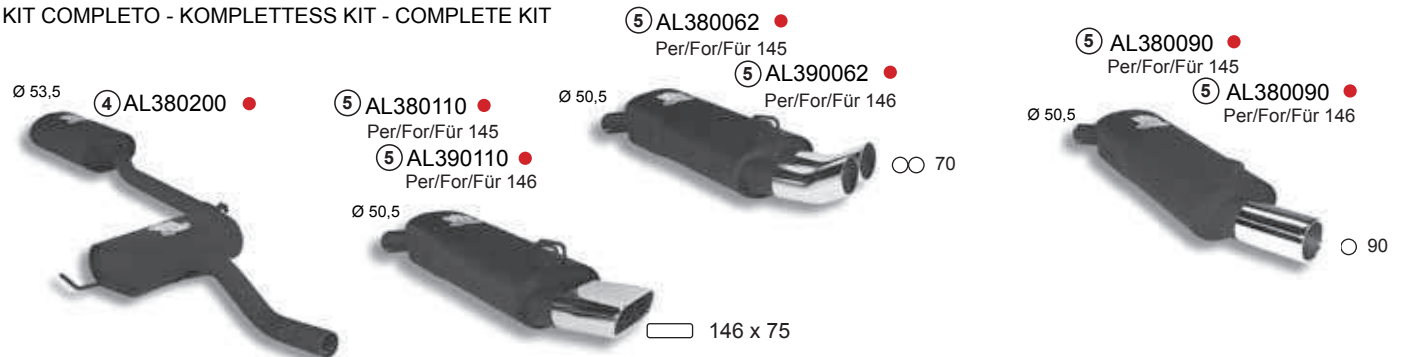

### NOTE

Le marmitte alluminizzate hanno tutti i tubi in acciaio INOX 304  
 Alle rohre der alluminierten schalldämpfer bestehen aus Edestahl AISI 304  
 All pipes of the alluminized exhausts are made of stainless steel AISI 304

● Omologato / EG-genehmigt - EU-approved

△ Con modifica paraurti /  
 Änderung der heckschürze / Rear bumper must be cut to fit

★ \* Acciaio INOX AISI 304 /  
 Edelstahl AISI 304 / Stainless steel AISI 304

## 147 1.6 - 2.0 - 2.0 SELESPEED (kW 77 - 88 - 110)

10/00 &gt; 11/04

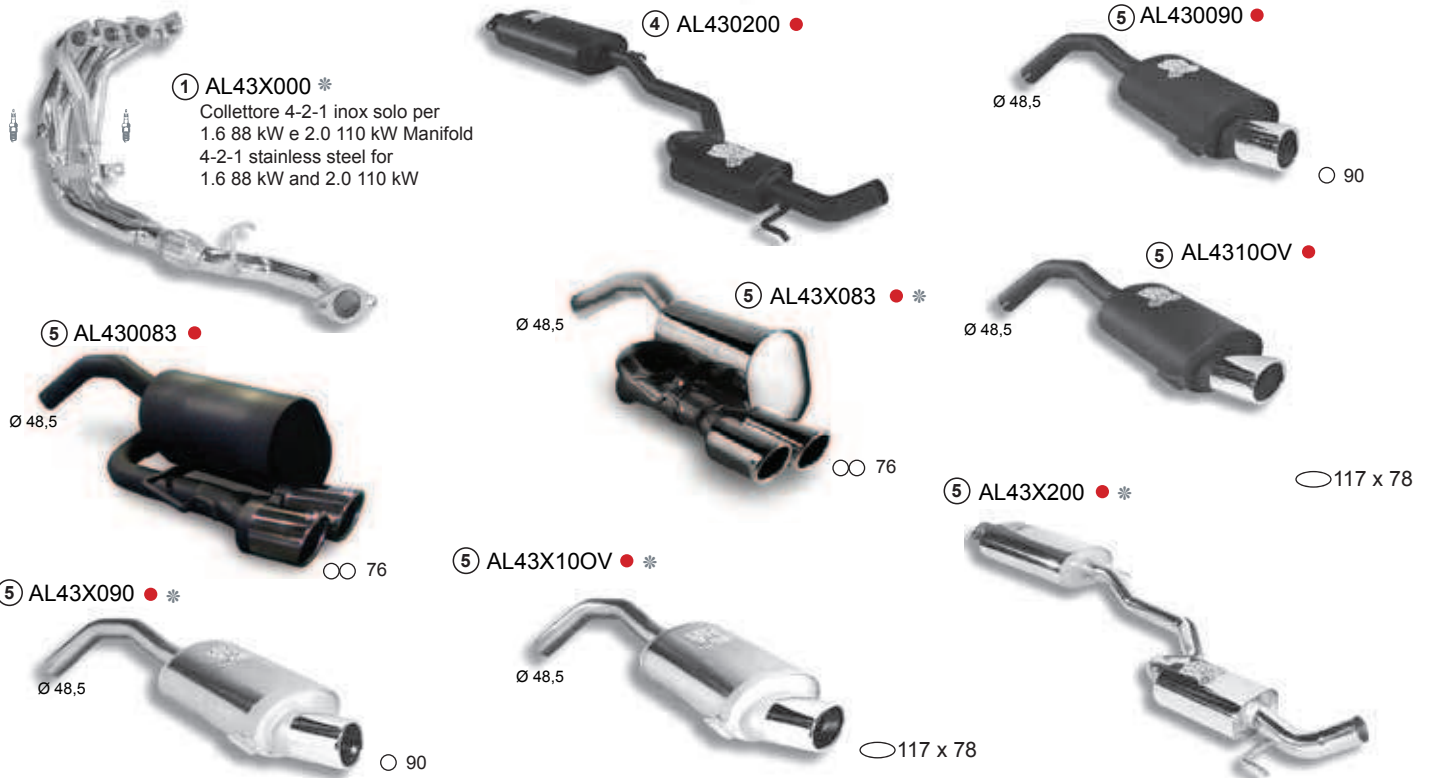

## 147 3.2 GTA

11/02 &gt; 01/06

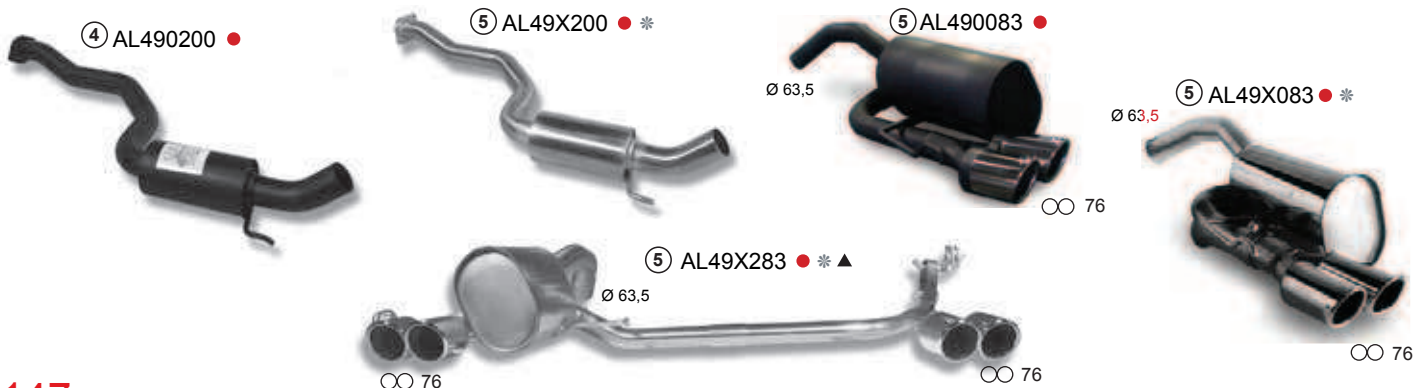

## 147 1.9 8/16v JTD MULTIJET 140cv 16v (kW 74 - 85 - 103)

10/00 &gt; 3/03



① Collettore / Fächerkrümmer / Manifold - Down pipe

④ Centrale / Mittelschalldämpfer / Center silencer - pipe

② Sport metal kat 200 cell

⑤ Posteriore / Endschalldämpfer / Rear silencer - pipe

③ Anteriore / Vorshalldämpfer / Front silencer



Sonda Lambda

## 147 1.6 - 2.0i (kW 77 - 88 - 110)

11/'04 >

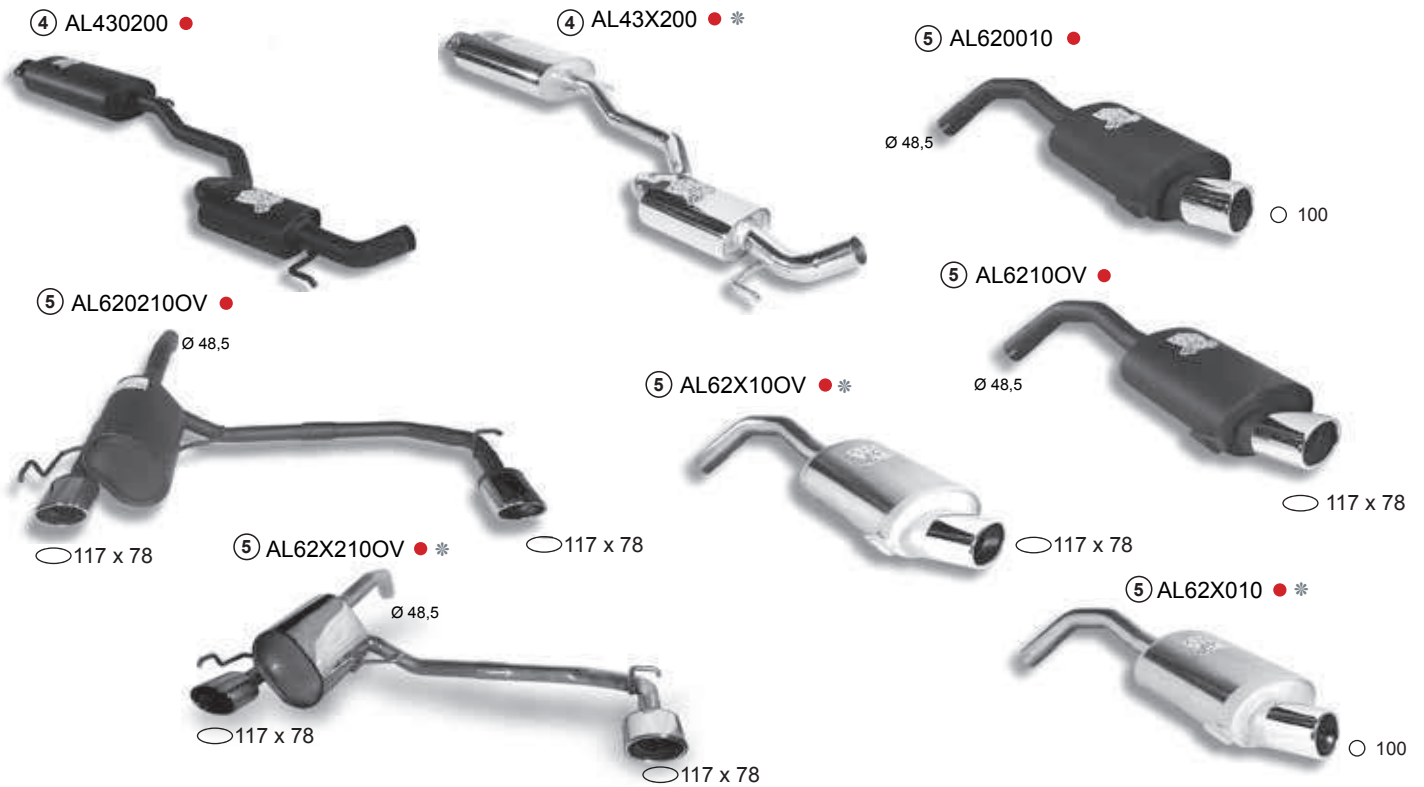

## 147 1.9 JTD MULTIJET (kW 74 - 85 - 110)

04/'03 >

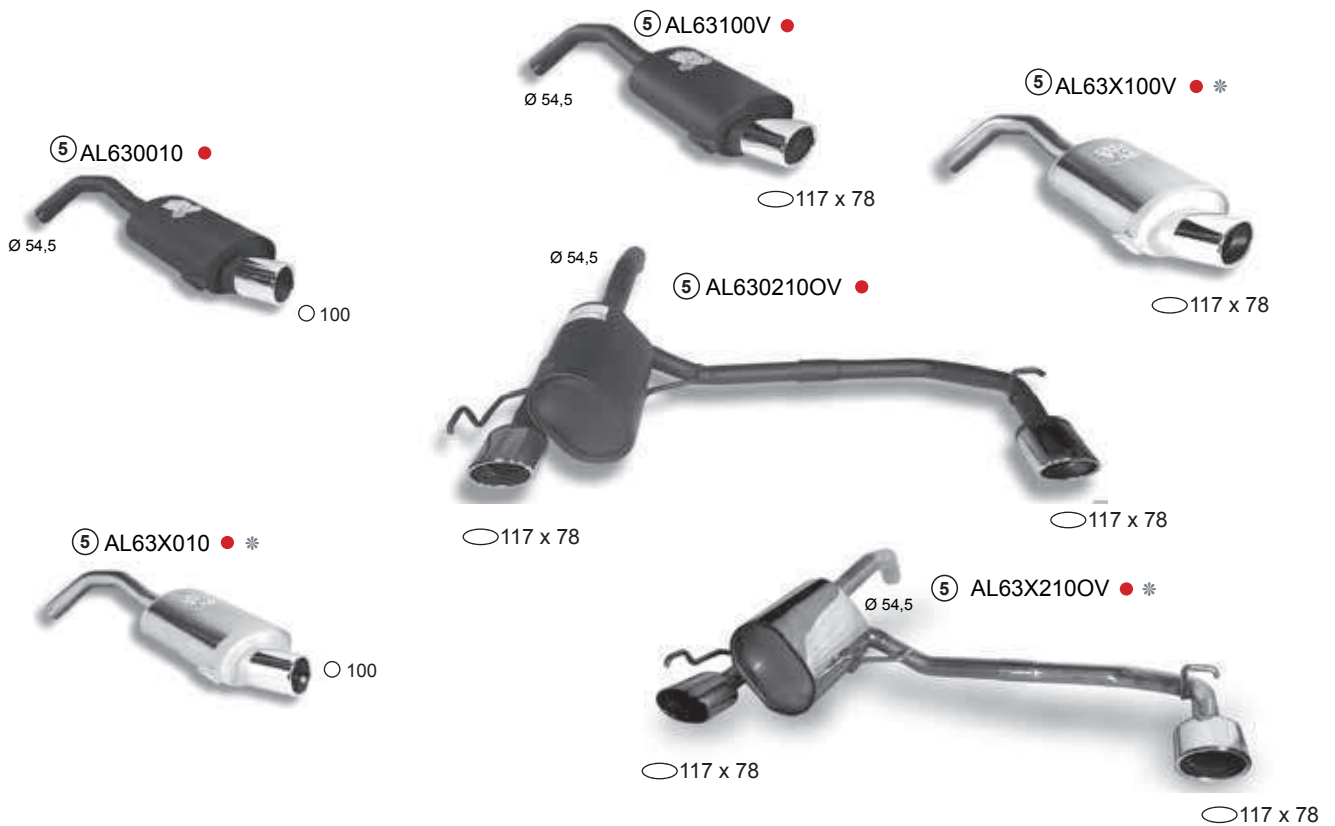

### NOTE

Le marmitte alluminate hanno tutti i tubi in acciaio INOX 304  
 Alle rohre der alluminierten schalldampfer bestehen aus Edestahl AISI 304  
 All pipes of the alluminized exhausts are made of stainless stell AISI 304

● Omologato / EG-genehmigt - EU-approved

△ Con modifica paraurti /  
 Änderung der heckschürze / Rear bumper must be cut to fit

\* Acciaio INOX AISI 304 /  
 \* Edelstahl AISI 304 / Stainless stell AISI 304

**155** 1.8 Cat. - 2.0i T.S. Cat. (kW 95 - 105) '92 > '96  
2.5 V6 (kW 120) '92 > '97

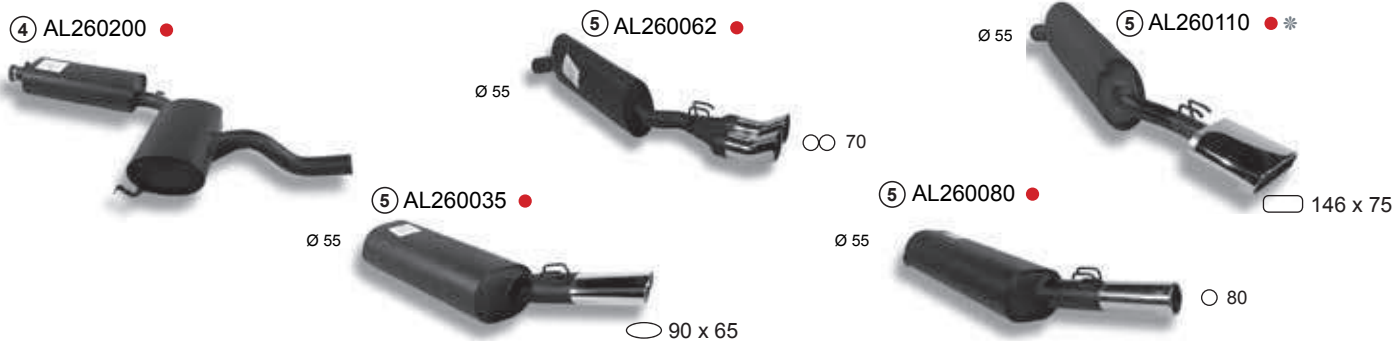

**155** 2.0i 16v T.S. SUPER 04/'95 > '96

KIT COMPLETO - KOMPLETTESS KIT - COMPLETE KIT



**155** 1.6 - 1.8 - 2.0 16V T.S. 05/'96 > '97

KIT COMPLETO - KOMPLETTESS KIT - COMPLETE KIT

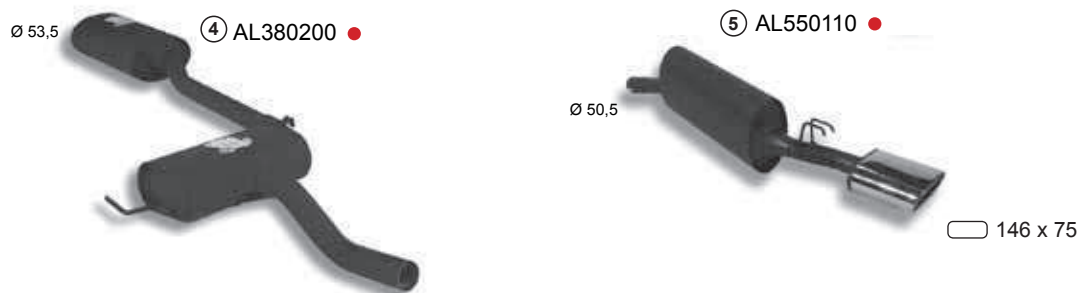

**155** 2.0i TURBO 16 v Q4 '92 > '97



- ① Collettore / Fächerkrümmer / Manifold - Down pipe
- ② Sport metal kat 200 cell
- ③ Anteriore / Vorshalldämpfer / Front silencer
- ④ Centrale / Mittelschalldämpfer / Center silencer - pipe
- ⑤ Posteriore / Endshalldämpfer / Rear silencer - pipe



Sonda Lambda

**156** T.S. 16v 1.6 - 1.8 - 2.0 + Sportwagon (kW 88 - 103 - 114) 10/'97 > 11/'00  
 T.S. 16v 1.6 - 1.8 - 2.0 + Sportwagon (kW 88 - 103 - 114) 11/'00 >



**156** GTA 3.2 + Sportwagon (kW 132) 06/'03 > 01/'06



**156** 2.5 V6 24v + Sportwagon (kW 141) 10/'97 >  
 2.0 JTS 16v + Sportwagon (kW 122) 03/'02 >



**156** 1.9 8/16v JTD - 2.4 JTD + Sportwagon (kW 88 - 103 - 110) '92 > '97



**NOTE**

Le marmitte alluminizzate hanno tutti i tubi in acciaio INOX 304  
 Alle rohre der alluminierten schalldampfer bestehen aus Edestahl AISI 304  
 All pipes of the alluminized exhausts are made of stainless steel AISI 304

● Omologato / EG-genehmigt - EU-approved

Δ Con modifica paraurti /  
 Änderung der heckschürze / Rear bumper must be cut to fit

\* Acciaio INOX AISI 304 /  
 Edestahl AISI 304 / Stainless steel AISI 304

**159** 1.8 - 1.9 JTS (kW 103 - 118) '05 >

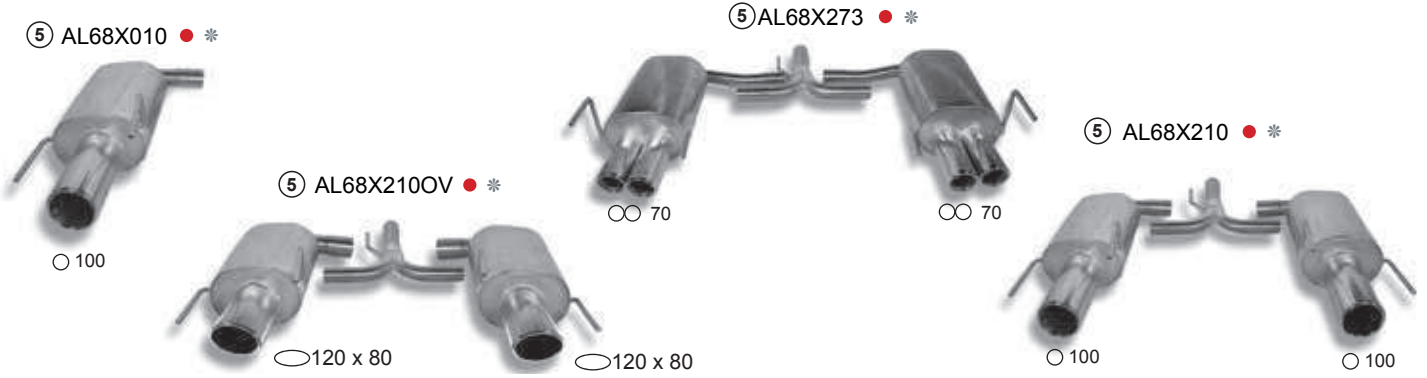

**159** 1.9 JTD (k 88 - 110) '05 >



**159** 2.2 JTS - 3.2 JTS (kW 136 -147 -154 -191) '05 >  
1.8 TBi (kW 147) 05/ '09 >



**159** 2.4 JTD (kW 147 - 154) '05 >



- ① Collettore / Fächerkrümmer / Manifold - Down pipe
- ② Sport metal kat 200 cell
- ③ Anteriore / Vorshalldämpfer / Front silencer
- ④ Centrale / Mittelschalldämpfer / Center silencer - pipe
- ⑤ Posteriore / Endshalldämpfer / Rear silencer - pipe



Sonda Lambda

**164** 2.0i T.S. (1962cc - 1995cc) 12/'90 > '92  
 2.0i TURBO '88 > 06/'90

⑤ AL21100V ●



○ 117 x 78

⑤ AL210032 ●



○ 60

**164** 2.0 T.S. Cat. '87 > '98

④ AL420200 ●



⑤ AL210032 ●



○ 60

⑤ AL21100V ●



○ 117 x 78

**164** 2.0 T.S. Cat. SUPER - 3.0i V6 Cat. SUPER 09/'92 > '98

⑤ AL420110 ●



○ 146 x 75

⑤ AL42100V ●



○ 117 x 78

⑤ AL420200 ●



**164** 3.0i V6 Q.Verde Cat. '90 > 08/'92

⑤ AL210032 ●



○ 60

⑤ AL21100V ●



○ 117 x 78

④ AL040200 ●



#### NOTE

Le marmitte alluminizzate hanno tutti i tubi in acciaio INOX 304  
 Alle rohre der alluminierten schalldampfer bestehen aus Edestahl AISI 304  
 All pipes of the alluminized exhausts are made of stainless steel AISI 304

● Omologato / EG-genehmigt - EU-approved

△ Con modifica paraurti /  
 Änderung der heckschürze / Rear bumper must be cut to fit

\* Acciaio INOX AISI 304 /  
 Edelstahl AISI 304 / Stainless steel AISI 304

**166** 2.0 16v T.S. 10/'98 >  
2.4 JTD 10/'97 >

④ AL400200 ●



⑤ AL40100V ●



○ 117 x 78

⑤ AL400090 ●



○ 90

**166** 2.0 V6 TURBO - 2.5 3.0 V6 24V 10/'98 >

④ AL530200 ●



⑤ AL530083 ●



○ 76

**ALFETTA** 1.6 - 1.8 - 2.0 (kW 81 - 87 - 95) '72 > '85



① AL02X000 \*  
Collettore/Manifold 4-2-1  
Esclude il silenziatore anteriore  
Front silencer replacement

③ AL020100 ●



Ø 50,5

⑤ AL020031 ●

Ø 45,5



○ 45

④ AL020200 ●



**ALFETTA** 1.6 GT - 1.8 - 2.0 GTV (kW 81 - 87 - 95) '72 > '85



① AL06X000 \*  
Collettore/Manifold 4-2-1  
Esclude il silenziatore anteriore  
Front silencer replacement

Ø 45,5

⑤ AL060032 ●



Ø 45,5

⑤ AL060031 ●



○ 45

Ø 50,5

④ AL060200 ●



○ 45

⑤ AL060100 ●



① Collettore / Fächerkrümmer / Manifold - Down pipe

④ Centrale / Mittelschalldämpfer / Center silencer - pipe

② Sport metal kat 200 cell

⑤ Posteriore / Endshalldämpfer / Rear silencer - pipe

③ Anteriore / Vorshalldämpfer / Front silencer



Sonda Lambda

**GIULIA** 1.3 - 1.3 Ti - 1.6 - 1.6 Ti - 1.6 SUPER

'70 &gt; '78

(1300cc - 1560cc)



Ø 50,5

**GIULIA** 1.8 - 2.0

'71 &gt; '76

**GIULIA** 2.0 con motore TwinSpark

'71 &gt; '76

KIT COMPLETO - KOMPLETTESS KIT - COMPLETE KIT Ø 60



④ AL002TS

**GIULIA** GTA

③ AL02XGTA \*

**NOTE**

Le marmite alluminate hanno tutti i tubi in acciaio INOX 304  
Alle rohre der alluminierten schalldampfer bestehen aus Edestahl AISI 304  
All pipes of the alluminized exhausts are made of stainless stell AISI 304

● Omologato / EG-genehmigt - EU-approved

△ Con modifica paraurti /  
Anderung der heckschürze / Rear bumper must be cut to fit

\* Acciaio INOX AISI 304 /  
Edestahl AISI 304 / Stainless stell AISI 304

<b>GTV / SPIDER</b>	T.S. 16v 1.8i - 2.0i	'95 >
<b>GTV</b>	3.0i V6 12v 24v	'95 >
<b>SPIDER</b>	3.0i V6 24v	'95 >
<b>GTV / SPIDER</b>	2.0i V6 TURBO	08/'99 >

③ AL460100



④ AL460200 ●



⑤ AL460072 ●



⑤ AL460062 ●



⑤ AL460110 ●



④ AL46X200 ●



⑤ AL46X262 ● \* Δ



**GTV / SPIDER 2.0i V6 TURBO** '95 > 07/'99

④ AL460200 ●



⑤ AL600110 ●

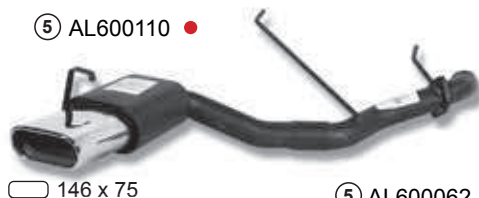

⑤ AL600072 ●



⑤ AL600062 ●



① Collettore / Fächerkrümmer / Manifold - Down pipe

④ Centrale / Mittelschalldämpfer / Center silencer - pipe

② Sport metal kat 200 cell

⑤ Posteriore / Endschalldämpfer / Rear silencer - pipe

③ Anteriore / Vorshalldämpfer / Front silencer



Sonda Lambda

**GT** 1.8i 16v T.S. - 2.0 JTS (kW 103 - 122) '03 >

**GT** 1.9 JTD (kW 110) '03 >

**GT** 3.2 GTA Coupè V6 (kW 176) '03 >

**GIULIETTA** SPIDER / SPRINT 1.3 - 1.6

IN PREPARAZIONE / IN VORBEREITUNG / AVAIIABLE SOON

**NOTE**

Le marmite alluminizzate hanno tutti i tubi in acciaio INOX 304  
 Alle rohre der alluminierten schalldampfer bestehen aus Edestahl AISI 304  
 All pipes of the alluminized exhausts are made of stainless stell AISI 304

● Omologato / EG-genehmigt - EU-approved

△ Con modifica paraurti /  
 Änderung der heckschürze / Rear bumper must be cut to fit

\* Acciaio INOX AISI 304 /  
 Edelstahl AISI 304 / Stainless stell AISI 304

## GIULIETTA II SERIE 1.3 - 1.6 - 1.8 - 2.0

④ AL030200  
Ø 45,5

⑤ AL030031



## GIULIETTA 1.4 TURBO (kW 88 - 125)

'10 &gt;

⑤ AL34X010 ● \*



Ø 50,5

⑤ AL34X210 ● \*

with original spoiler 2.0 JTDM

Ø 50,5

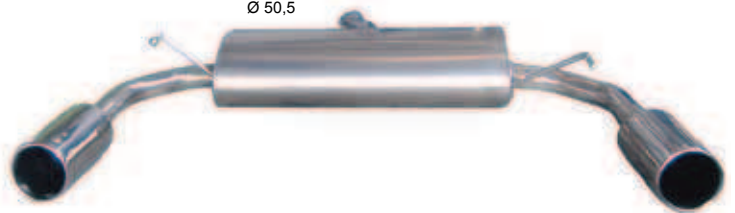

## GIULIETTA 1750 TBi (kW 173)

'10 &gt;

④ AL33X200



○ 100

⑤ AL33X210 ● \*

Ø 60,5

○ 100

## GIULIETTA 1.6 JTDm (kW 77)

'10 &gt;

⑤ AL32X010 ● \*



Ø 50,5

○ 100

⑤ AL32X210 ● \*

with original spoiler 2.0 JTDm

Ø 50,5



○ 100

○ 100

① Collettore / Fächerkrümmer / Manifold - Down pipe

④ Centrale / Mittelschalldämpfer / Center silencer - pipe

② Sport metal kat 200 cell

⑤ Posteriore / Endshalldämpfer / Rear silencer - pipe

③ Anteriore / Vorshalldämpfer / Front silencer



Sonda Lambda



## MITO 1.4 TURBO (kW 99 - 114 - 125)

09/'08 &gt;

② FI36XCT00K  
sport metal kat  
200 cell

④ FI36X200 ● \*

⑤ AL69X010A ● \*



④ FI36X2ST

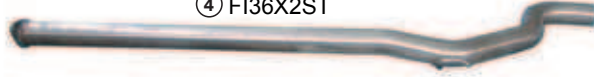

③ FI36X100



Ø 55

⑤ AL69X272 ● \* Δ

120 x 80



⑤ AL69X150OV ● \*

Ø 55



150 x 105

⑤ AL69X072 ● \*

Ø 55



Ø 76

⑤ AL69X210A ● \* Δ



120 x 80

120 x 80

## MITO 1.6 MULTIJET (kW 66 - 88)

09/'08 &gt;

⑤ AL73X010A ● \*

Ø 55



120 x 80

⑤ AL73X150OV ● \*



⑤ AL73X072 ● \*

Ø 55



Ø 76

Ø 55

⑤ AL73X272 ● \* Δ



Ø 76

Ø 76

Ø 55

⑤ AL73X210A ● \* Δ

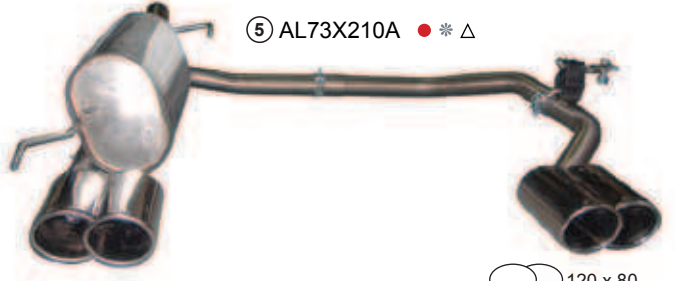

120 x 80

120 x 80

① Collettore / Fächerkrümmer / Manifold - Down pipe

④ Centrale / Mittelschalldämpfer / Center silencer - pipe

② Sport metal kat 200 cell

⑤ Posteriore / Endshaldämpfer / Rear silencer - pipe

③ Anteriore / Vorshaldämpfer / Front silencer



Sonda Lambda

BRERA 1750 TBI (147 kW)

'06 &gt;

SPIDER

⑤ AL74X273OV ● \*



∅ 70 x 80



∅ 70 x 80

BRERA 3.2 - 2.4 JTD

11/'05 &gt;

SPIDER

⑤ AL66X273OV ● \*



∅ 70 x 80



∅ 70 x 80

ZAGATO RZ / SZ 3.0 V6

'89 &gt; '93

∅ 48,5

④ AL54X200 ● \*



⑤ AL54X110 ● \*

∅ 60,5

∅ 146 x 75

**NOTE**

Le marmite alluminizzate hanno tutti i tubi in acciaio INOX 304

Alle röhre der alluminierten schalldämpfer bestehen aus Edelstahl AISI 304

All pipes of the alluminized exhausts are made of stainless steel AISI 304

● Omologato / EG-genehmigt - EU-approved

△ Con modifica paraurti /

Anderung der heckschürze / Rear bumper must be cut to fit

\* Acciaio INOX AISI 304 /  
Edelstahl AISI 304 / Stainless steel AISI 304

## A3 1.6 (kW 74)

09/'96 &gt; '02

④ AD140200 ●



⑤ AD140110 ●



⑤ AD140083 ●



⑤ AD140V82 ●



146 x 75

∅ 80

## A3 1.8 20V (kW 92)

09/'96 &gt; 02/'04

④ AD130200 ●



⑤ AD130110 ●



⑤ AD130V82 ●



146 x 75

⑤ AD130083 ●



∅ 80

## A3 1.8 i TURBO 20V - 1.9TDI (kW 74)

09/'96 &gt; 02/'04

④ AD150200 ●



⑤ AD150110 ●



⑤ AD150V82 ●



⑤ AD150083 ●



∅ 80

## A3 S3 1.8 - 4WD 6 M. 3 PORTE

11/'99 &gt; '02

⑤ AD17X082 ●\*



⑤ AD17X283 ●

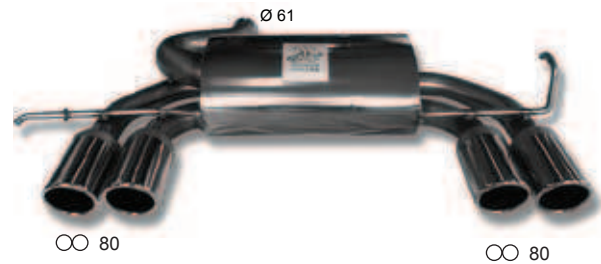

① Collettore / Fächerkrümmer / Manifold - Down pipe

④ Centrale / Mittelschalldämpfer / Center silencer - pipe

② Sport metal kat 200 cell

⑤ Posteriore / Endshaldämpfer / Rear silencer - pipe

③ Anteriore / Vorshaldämpfer / Front silencer



Sonda Lambda

**A3** 1.6 - 2.0 - 1.6 FSI - 2.0 FSI / SPORTBACK (kW 75 - 85 - 110) '03 >

1.9 TDI - 2.0 TDI / SPORTBACK (kW 77 - 100 - 103 125) '03 >

⑤ AD20X283ST \*  
Solo per / Nür für / Only for  
3 Porte - 3 Doors



⑤ AD20X283 ● \*  
Solo per / Nür für / Only for  
3 Porte - 3 Doors  
∅ 50 - 55 - 60



⑤ AD20X083 ● \*  
Solo per / Nür für / Only for  
3 Porte - 3 Doors  
∅ 50 - 55 - 60

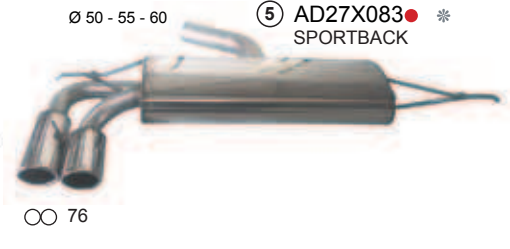

⑤ AD27X083 ● \*  
SPORTBACK

**A3** 2.0 TFSI / SPORTBACK (kW 147) '03 >



⑤ AD21X283 ● \* Δ  
Solo per / Nür für / Only for  
3 Porte - 3 Doors  
∅ 65



④ VO53X200 ● \*



⑤ AD28X283 ● \* Δ  
SPORTBACK



∅ 65



⑤ AD21X283ST \* Δ  
Solo per / Nür für / Only for  
3 Porte - 3 Doors



⑤ AD21X283ST ● \*  
Solo per / Nür für / Only for  
3 Porte - 3 Doors

⑤ AD28X283ST \* Δ  
SPORTBACK

⑤ AD28X283ST ● \*  
SPORTBACK

**A3** S3 2.0 TFSI 3 DOORS (kW 195) '07 >

**A3** S3 2.0 TFSI SPORTBACK (kW 195) '07 >

**A3** TFSI QUATTRO / SPORTBACK (kW 195) '07 >



⑤ AD23X082 ● \*  
S3 2.0 TFSI 3 DOOR  
S3 2.0 TFSI QUATTRO 3 DOORS  
∅ 65



CONTINUA / WEITER / CONTINUES >>

**NOTE**  
Le marmite alluminizzate hanno tutti i tubi in acciaio INOX 304  
Alle rohre der alluminierten schalldämpfer bestehen aus Edestahl AISI 304  
All pipes of the alluminized exhausts are made of stainless steel AISI 304

● Omologato / EG-genehmigt - EU-approved

Δ Con modifica paraurti /  
Anderung der heckschürze / Rear bumper must be cut to fit

\* Acciaio INOX AISI 304 /  
Edestahl AISI 304 / Stainless steel AISI 304

CONTINUA / WEITER / CONTINUES da / aus / from p.21 &gt;&gt;

## ⑤ AD29X082 ● \*

S3 2.0 TFSI 3 SPORTBACK  
S3 2.0 TFSI QUATTRO SPORTBACK

## ④ AD23X200 ● \*



## TT 1.8 T (kW 110 - 32)

'03 &gt;

KIT COMPLETO - KOMPLETTES KIT - COMPLETE KIT

## ③ + ② AD24X100K

Metallic Kat  
200 celle / cell / zellen

## ④ AD24X200ST

Ø 55

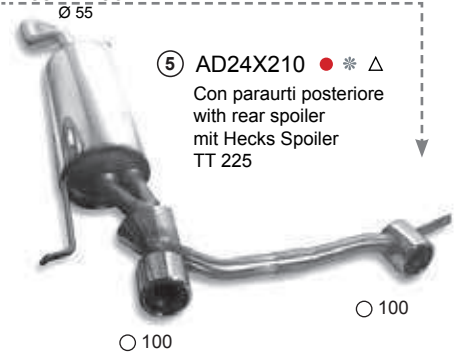

## ⑤ AD24X210 ● \* Δ

Con paraurti posteriore  
with rear spoiler  
mit Hecks Spoiler  
TT 225

## TT COUPÈ - ROADSTER (kW 165)

11/'01 &gt; 04/'03

## ⑤ AD16X102 ● \*

Ø 62,5



## TT QUATTRO 2.0 TFSI (kW 147 - 155)

'07 &gt;

## ⑤ AD22X210 ● \*

FOR ORIGINAL SPOILER "TT VR 6"



## ⑤ AD22X210OV ● \*

FOR ORIGINAL SPOILER "TT S"



## ⑤ AD22X283 ● \*

FOR ORIGINAL SPOILER "TT S"



① Collettore / Fächerkrümmer / Manifold - Down pipe

④ Centrale / Mittelschalldämpfer / Center silencer - pipe

② Sport metal kat 200 cell

⑤ Posteriore / Endshalldämpfer / Rear silencer - pipe

③ Anteriore / Vorshalldämpfer / Front silencer



Sonda Lambda

**TT** QUATTRO 2.0 TDI (kW 125) '07 >

⑤ AD30X210 ● \*  
FOR ORIGINAL SPOILER "TT VR 6"



⑤ AD30X210OV ● \*  
FOR ORIGINAL SPOILER "TT S"



⑤ AD30X283 ● \*  
FOR ORIGINAL SPOILER "TT S"



**R8** 4.2 V8 (kW 309) '07 >

⑤ AD26X283 \*



**S4** 4.2 (kW 253) '04 > '08

④ AD25X200 \* ●



③ AD25X100L \*

③ AD25X100R \*

Foto non disponibile  
Foto nicht verfügbar  
Picture not available

② AD25XCT00KL \*

② AD25XCT00KR \*

⑤ AD25X212R \* ●



⑤ AD25X212L \* ●



⑤ AD25X2110L \* ●



⑤ AD25X2110R \* ●



**Q3** 2.0 TDI / 2.0 TDI QUATTRO (kW 140)

⑤ AD31X086OV \* ●



⑤ AD31X286OV \* ●



○ 90x80

**NOTE**

Le marmitte alluminizzate hanno tutti i tubi in acciaio INOX 304  
Alle rohre der alluminierten schalldampfer bestehen aus Edestahl AISI 304  
All pipes of the alluminized exhausts are made of stainless stell AISI 304

● Omologato / EG-genehmigt - EU-approved

△ Con modifica paraurti /  
Anderung der heckschürze / Rear bumper must be cut to fit

\* Acciaio INOX AISI 304 /  
Edelstahl AISI 304 / Stainless stell AISI 304

**Q3 2.0 TURBO** (kW 125 - 155)

⑤ AD32X086OV \* ●



○○ 90x80

⑤ AD32X286OV \* ●



○○ 90x80

○○ 90x80

① Collettore / Fächerkrümmer / Manifold - Down pipe

④ Centrale / Mittelschalldämpfer / Center silencer - pipe

② Sport metal kat 200 cell

⑤ Posteriore / Endshalldämpfer / Rear silencer - pipe

③ Anteriore / Vorshalldämpfer / Front silencer



Sonda Lambda

**A112** ABARTH (1050cc - 70 hp) 09/'75 > 06/'86

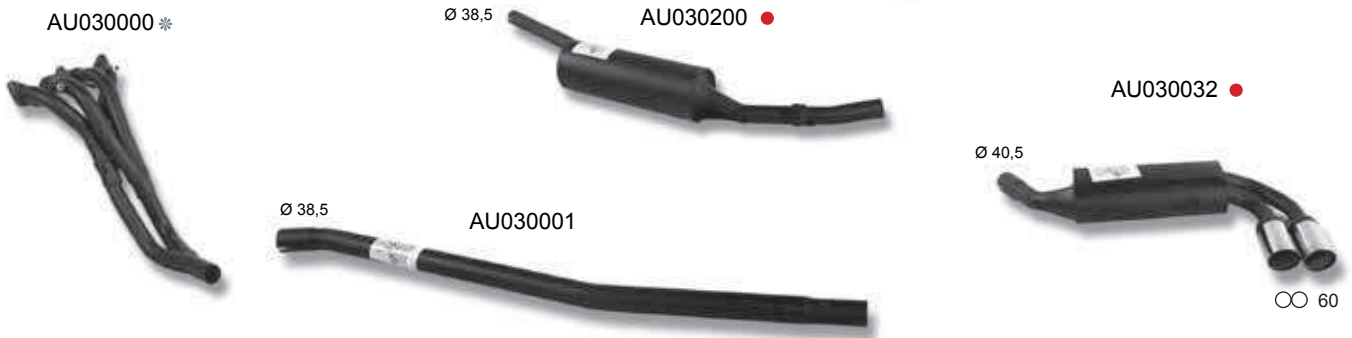

**Y10** FIRE 1.0 ie (999cc - 45hp) 02/'85 > '92

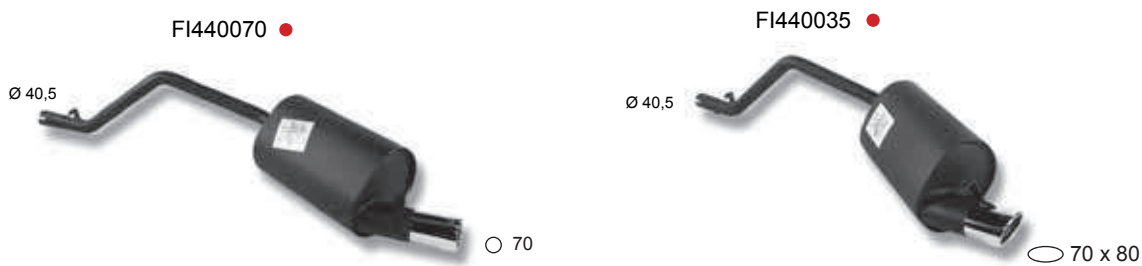

**Y10** 1.1 ie (1108cc - 50hp) 10/'92 > 02/'94



**NOTE**

Le marmite alluminate hanno tutti i tubi in acciaio INOX 304  
 Alle rohre der alluminierten schalldampfer bestehen aus Edestahl AISI 304  
 All pipes of the alluminized exhausts are made of stainless stell AISI 304

● Omologato / EG-genehmigt - EU-approved

△ Con modifica paraurti /  
 Aenderung der heckschürze / Rear bumper must be cut to fit

\* Acciaio INOX AISI 304 /  
 Edestahl AISI 304 / Stainless stell AISI 304

## Serie 02 E 10 1502 - 1600/2 - 1602 - 1802 - 2002/Ti

04/'69 &gt; 1977

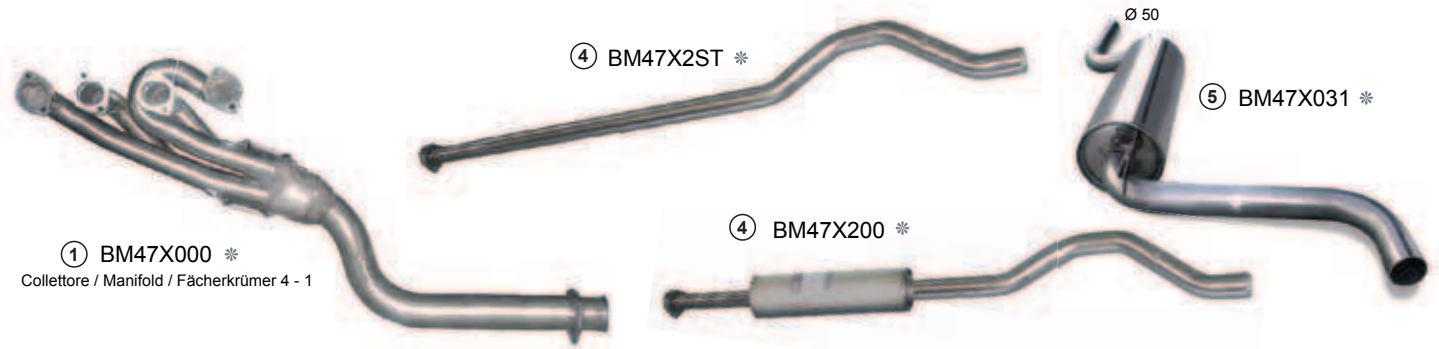

## Z1 2.5 (kW 125)

'88 &gt; '91

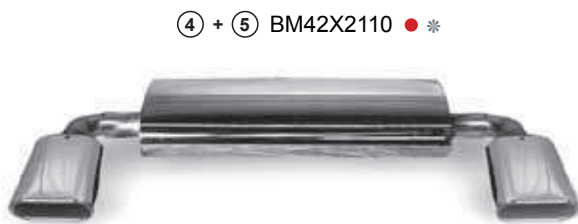

## Z4 2.5 - 3.0 (kW 130 - 160 - 195)

06/'02 &gt;

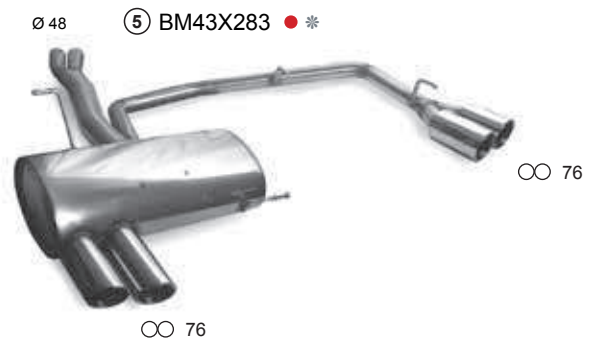

## E87 116 - 118 - 120 (kW 85 - 90 - 100 - 105 - 120 - 130)

'04 &gt;



① Collettore / Fächerkrümer / Manifold - Down pipe

④ Centrale / Mittelschalldämpfer / Center silencer - pipe

② Sport metal kat 200 cell

⑤ Posteriore / Endshalldämpfer / Rear silencer - pipe

③ Anteriore / Vorshalldämpfer / Front silencer



Sonda Lambda

**E91** TOURING 318D - 320D (kW 85 - 90 - 100 - 105 - 120 - 130)

'04 >

⑤ BM48X0730V ● \*



∅ 70 x 80

**M3** E 46 Serie 3 CI COUPÈ 6M

'99 >

⑤ BM32X470 \*



∅ 70

∅ 70

**M3** E92 (kW 309)

'98 >

KIT COMPLETO - KOMPLETTES KIT - COMPLETE KIT

③ BM40X100R \*

④ + ② BM40X200 \*

③ BM40X100L \*

⑤ BM40X286 ● \*

⑤ BM43X286 ● \*



∅ 86

Solo per / Nür für / Only for  
Impianto originale  
Original system

∅ 86

∅ 86

∅ 86

**M5** E 39 5.0 6M

'98 >

⑤ BM27XD92

∅ 63,5

∅ 63,5



∅ 90

⑤ BM27XS92

∅ 90

**NOTE**

Le marmitte alluminizzate hanno tutti i tubi in acciaio INOX 304  
Alle rohre der alluminierten schalldämpfer bestehen aus Edelstahl AISI 304  
All pipes of the alluminized exhausts are made of stainless steel AISI 304

● Omologato / EG-genehmigt - EU-approved

△ Con modifica paraurti /  
Anderung der heckschürze / Rear bumper must be cut to fit

\* Acciaio INOX AISI 304 /  
Edelstahl AISI 304 / Stainless steel AISI 304

**M6** COUPÈ E63 (kW 373)

'06 &gt;

⑤ BM37X212 ● \*

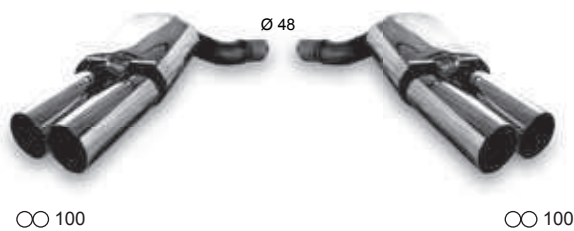
**X5** E 53 3.0i - 3.0 d (kW 135 - 160 - 170)

'00 &gt; '06

⑤ BM35X2121 ● \*

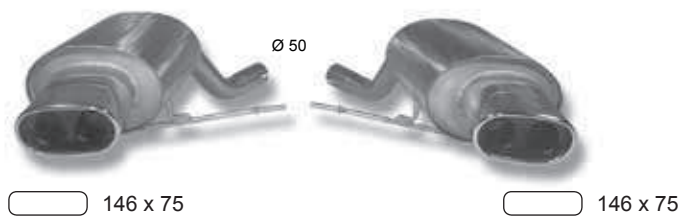
**X5** E70 3.0d - 3.0 d (kW 135 - 160 - 170)

'07 &gt;

⑤ BM46X476R \*

⑤ BM46X476L \*

**X6** E71 3.0d - 3.5 d (kW 173 - 210)

06/'08 &gt;

⑤ BM45X476R \*

⑤ BM45X476L \*



① Collettore / Fächerkrümmer / Manifold - Down pipe

④ Centrale / Mittelschalldämpfer / Center silencer - pipe

② Sport metal kat 200 cell

⑤ Posteriore / Endshaldämpfer / Rear silencer - pipe

③ Anteriore / Vorshaldämpfer / Front silencer



Sonda Lambda

## C1 1.0 (kW 50)

03/'96 > '00



## C2 - C3

1.1 (kW 50)

2002 >

1.4 - 1.4 VTR (kW 54)

2002 >



## C2 - C3

1.6 VTR - VTS (kW 80)

2002 >

① CI14X000 \*  
Solo per / Nür für / Only for  
1.6 8V



① CI16X000 \*  
Solo per / Nür für / Only for  
1.6 16V



## C2 1.4 VTR

2002 >

NON ADATTABILE AI RICAMBI ORIGINALI / UNSUITABLE FOR ORIGINAL SPARE PARTS

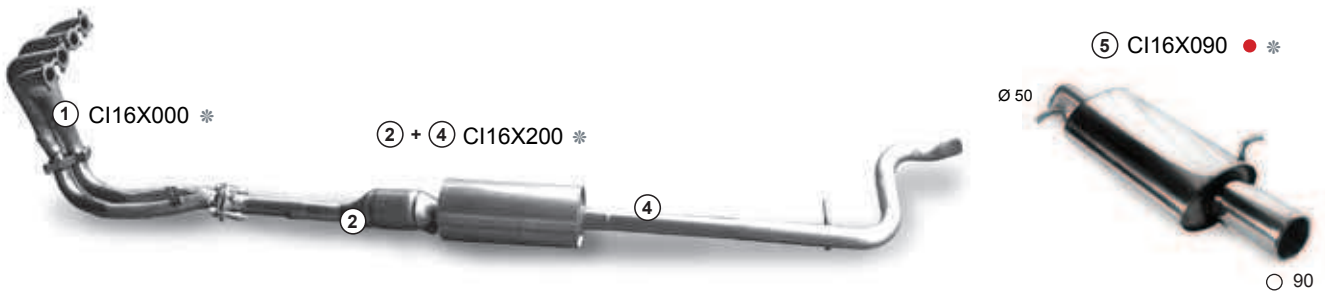

### NOTE

Le marmitte alluminizzate hanno tutti i tubi in acciaio INOX 304  
Alle rohre der alluminierten schalldämpfer bestehen aus Edestahl AISI 304  
All pipes of the alluminized exhausts are made of stainless steel AISI 304

● Omologato / EG-genehmigt - EU-approved

△ Con modifica paraurti /  
Anderung der heckschürze / Rear bumper must be cut to fit

\* Acciaio INOX AISI 304 /  
Edestahl AISI 304 / Stainless steel AISI 304

## DS3 1.4 / 1.6 (kW 70 - 88)

2010 &gt;

Ø 45/50

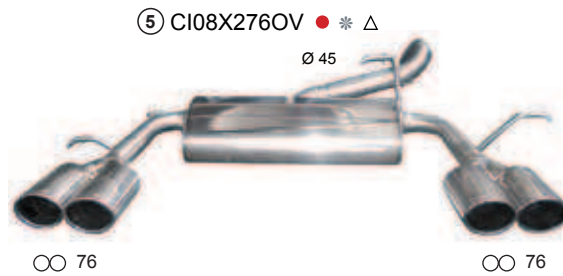

## DS3 1.6 Turbo (kW 115)

2010 &gt;

Ø 50

② + ③ BM36X100K \*

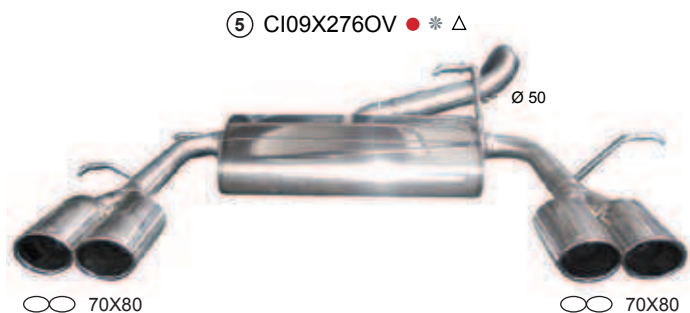

## DS3 1.4 / 1.6 HDI (kW 50-80)

2010 &gt;

⑤ CI07X076OV ● \*

Ø 42-45

70X80

⑤ CI07X276OV ● \* Δ

Ø 42-45

70X80

70X80

2010 >

① Collettore / Fächerkrümmer / Manifold - Down pipe

④ Centrale / Mittelschalldämpfer / Center silencer - pipe

② Sport metal kat 200 cell

⑤ Posteriore / Endshalldämpfer / Rear silencer - pipe

③ Anteriore / Vorshalldämpfer / Front silencer

Sonda Lambda

**CSC MARMITTE** ITALIA

## 328 GTB - GTS

'85 >



## 328 cat

'85 >

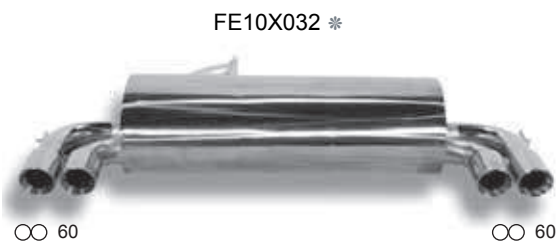

## 348 cat TB - TS

'89 >



## F 355 1° SERIE



### NOTE

Le marmitte alluminizzate hanno tutti i tubi in acciaio INOX 304  
Alle rohre der alluminierten schalldampfer bestehen aus Edestahl AISI 304  
All pipes of the alluminized exhausts are made of stainless stell AISI 304

● Omologato / EG-genehmigt - EU-approved

△ Con modifica paraurti /  
Anderung der heckschürze / Rear bumper must be cut to fit

\* Acciaio INOX AISI 304 /  
Edelstahl AISI 304 / Stainless stell AISI 304

## 360 MODENA F1 6 Marce / SPIDER

FORMULA CHALLENGER

FE08X032 \*



## 512 TESTA ROSSA Cat

FE05XCTDS \*



FE05X032 \*



## DINO 246 GT

'72 &gt; '74

FE09X032 \*



## MONDIAL 8 3000 4v / 3200 4v

'80 &gt; '93

FE02X032 \*



① Collettore / Fächerkrümmer / Manifold - Down pipe

④ Centrale / Mittelschalldämpfer / Center silencer - pipe

② Sport metal kat 200 cell

⑤ Posteriore / Endshalldämpfer / Rear silencer - pipe

③ Anteriore / Vorshalldämpfer / Front silencer



Sonda Lambda

**MONDIAL** T 3200 4v

'80 > '93

FE04XCTDS \*



FE04X032 \*

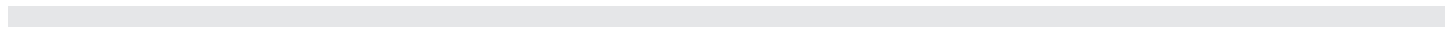
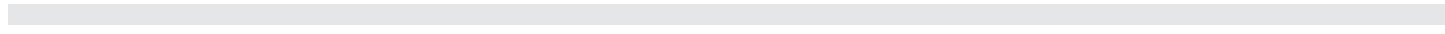
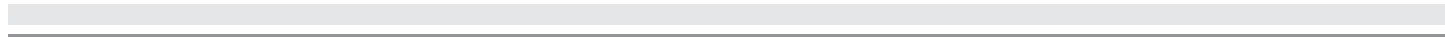

**NOTE**

Le marmitte alluminate hanno tutti i tubi in acciaio INOX 304  
 Alle rohre der alluminierten schalldampfer bestehen aus Edestahl AISI 304  
 All pipes of the alluminized exhausts are made of stainless stell AISI 304

● Omologato / EG-genehmigt - EU-approved

△ Con modifica paraurti /  
 Aenderung der heckschürze / Rear bumper must be cut to fit

\* Acciaio INOX AISI 304 /  
 Edelstahl AISI 304 / Stainless stell AISI 304

## 124 1.4 - 1.6 spider europa

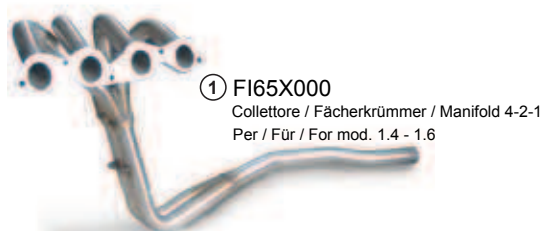

## 124 2.0 spider america



## 127 SPORT 70 HP 1050

'78 &gt; '81

NON ADATTABILE AI RICAMBI ORIGINALI / UNSUITABLE FOR ORIGINAL SPARE PARTS



## 127 SPORT 75 HP 1300

01/'82 &gt; '84

NON ADATTABILE AI RICAMBI ORIGINALI / UNSUITABLE FOR ORIGINAL SPARE PARTS



① Collettore / Fächerkrümmer / Manifold - Down pipe

④ Centrale / Mittelschalldämpfer / Center silencer - pipe

② Sport metal kat 200 cell

⑤ Posteriore / Endshaldämpfer / Rear silencer - pipe

③ Anteriore / Vorshaldämpfer / Front silencer



Sonda Lambda

**128 BERLINA** 1100cc - 1300cc

'69 > '85

NON ADATTABILE AI RICAMBI ORIGINALI / UNSUITABLE FOR ORIGINAL SPARE PARTS



① FI080000 \*  
Collettore / Manifold 4 - 2 - 1



Ø 45      ④ + ⑤ FI080001

X 1/9

11/'72 > '88



FI350031

○ 45



⑤ FI350460

○○ 60

○○ 60

X 1/9

11/'72 > '88

KIT COMPLETO - KOMPLETTESS KIT - COMPLETE KIT



① FI280000 \*  
Collettore / Manifold 4 - 2 - 1



⑤ FI280031

X 1/9 america 1.5 cat

11/'72 > '88

KIT COMPLETO - KOMPLETTESS KIT - COMPLETE KIT



① FI29X000 \*



② + ⑤ FI29X031 \*  
Sport Metal Cat 200 celle interno

**NOTE**

Le marmitte alluminizzate hanno tutti i tubi in acciaio INOX 304  
Alle rohre der alluminierten schalldampfer bestehen aus Edestahl AISI 304  
All pipes of the alluminized exhausts are made of stainless steel AISI 304

● Omologato / EG-genehmigt - EU-approved

△ Con modifica paraurti /  
Anderung der heckschürze / Rear bumper must be cut to fit

\* Acciaio INOX AISI 304 /  
Edestahl AISI 304 / Stainless steel AISI 304

## 500 F - L

'60 &gt; '73

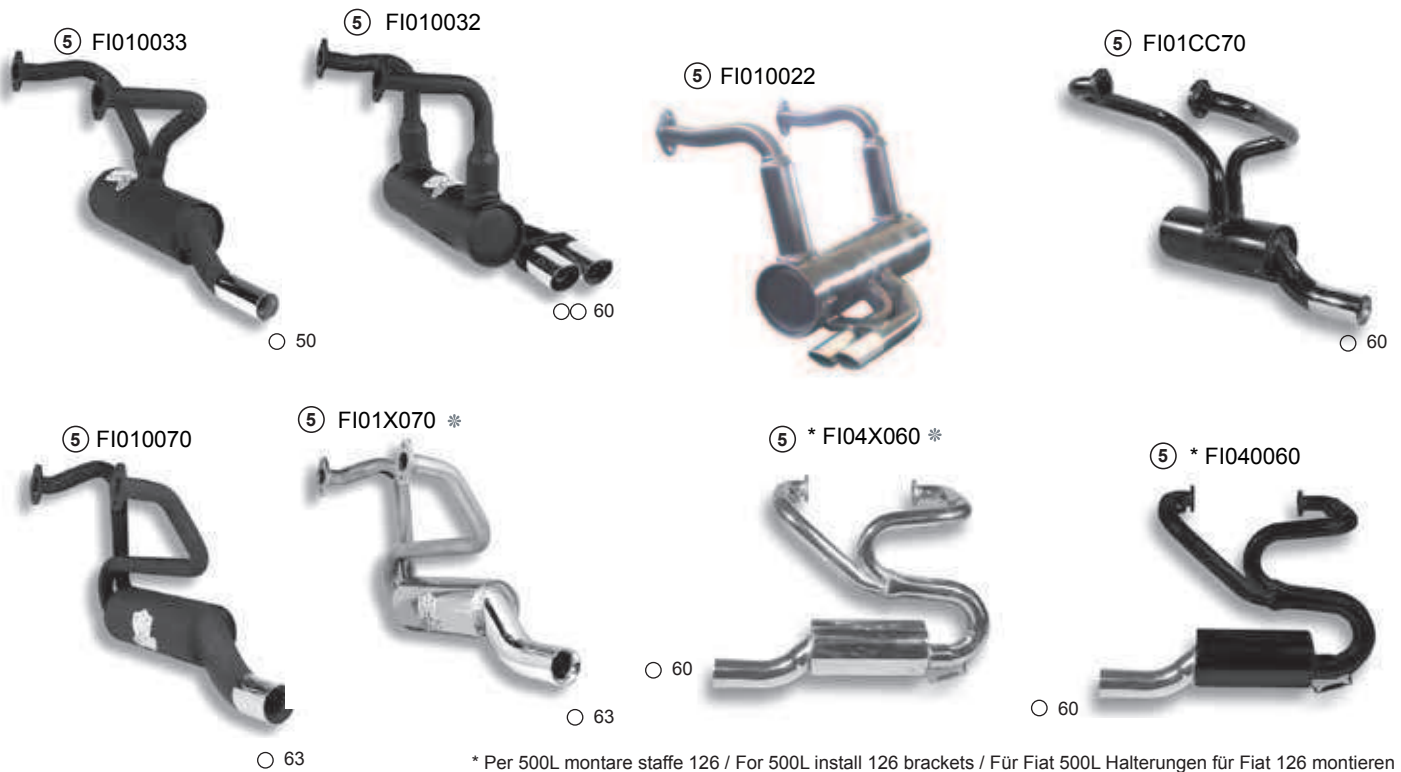

\* Per 500L montare staffe 126 / For 500L install 126 brackets / Für Fiat 500L Halterungen für Fiat 126 montieren

\* Modifica convogliatore aria / Air conveyor to be modified / Änderung der Airbox erforderlich

## 500 R

'72 &gt; '75

## 126

'72 &gt; '87

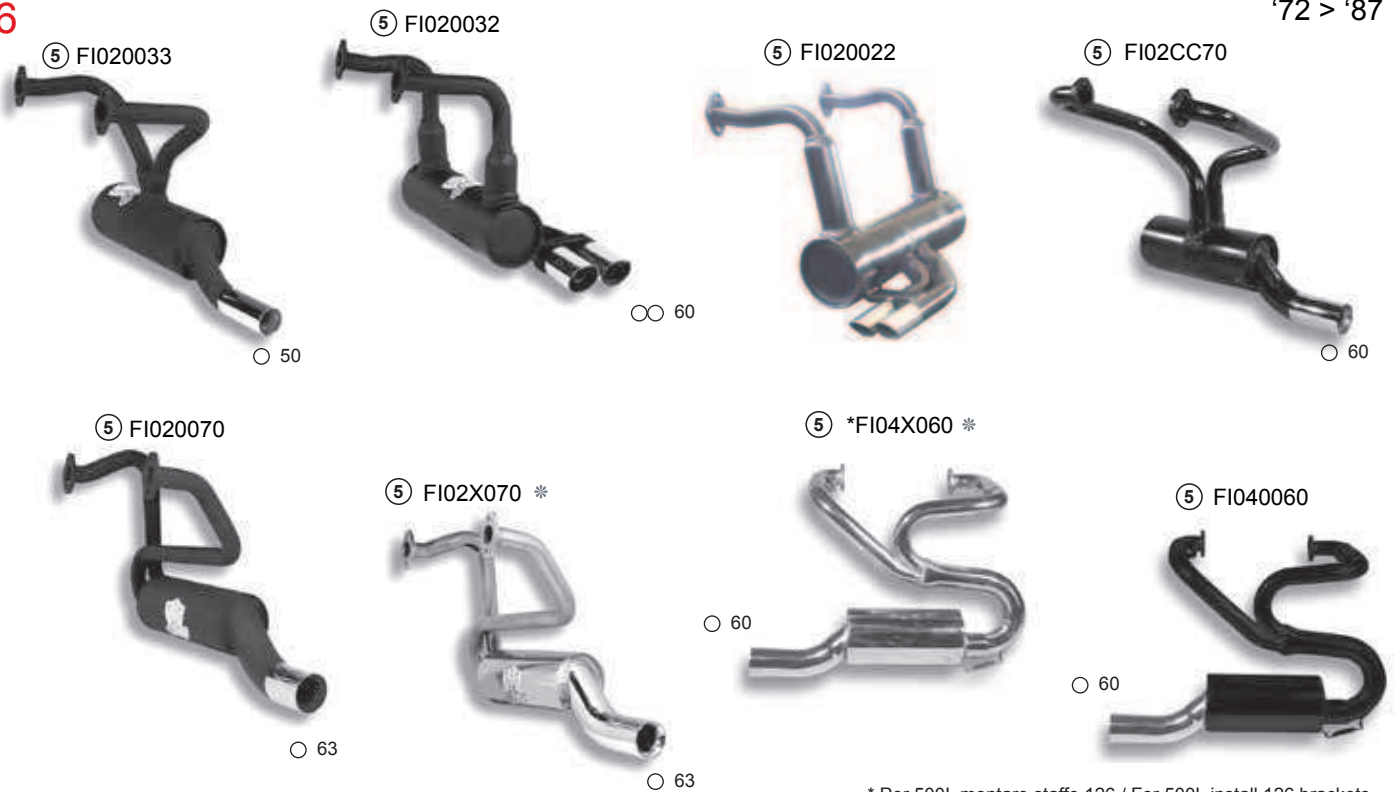

\* Per 500L montare staffe 126 / For 500L install 126 brackets

① Collettore / Fächerkrümmer / Manifold - Down pipe

④ Centrale / Mittelschalldämpfer / Center silencer - pipe

② Sport metal kat 200 cell

⑤ Posteriore / Endschalldämpfer / Rear silencer - pipe

③ Anteriore / Vorshalldämpfer / Front silencer



Sonda Lambda

850 Coupé



X 1/9 america 1.5 cat

11/'72 > '88

KIT COMPLETO - KOMPLETTESS KIT - COMPLETE KIT



② + ⑤ FI29X031 \*  
Sport Metal Cat 200 celle interno



BARCETTA

1.8 16v

'95 >



NOTE

Le marmite alluminate hanno tutti i tubi in acciaio INOX 304  
 Alle rohre der alluminierten schalldampfer bestehen aus Edestahl AISI 304  
 All pipes of the alluminized exhausts are made of stainless stell AISI 304

● Omologato / EG-genehmigt - EU-approved

△ Con modifica paraurti /  
 Änderung der heckschürze / Rear bumper must be cut to fit

\* Acciaio INOX AISI 304 /  
 Edelstahl AISI 304 / Stainless stell AISI 304

**BRAVO/BRAVA** 1.4 12V - 1.6 16V - 1.8 16V - 115 6V

08/'95 &gt;

KIT COMPLETO - KOMPLETTESS KIT - COMPLETE KIT

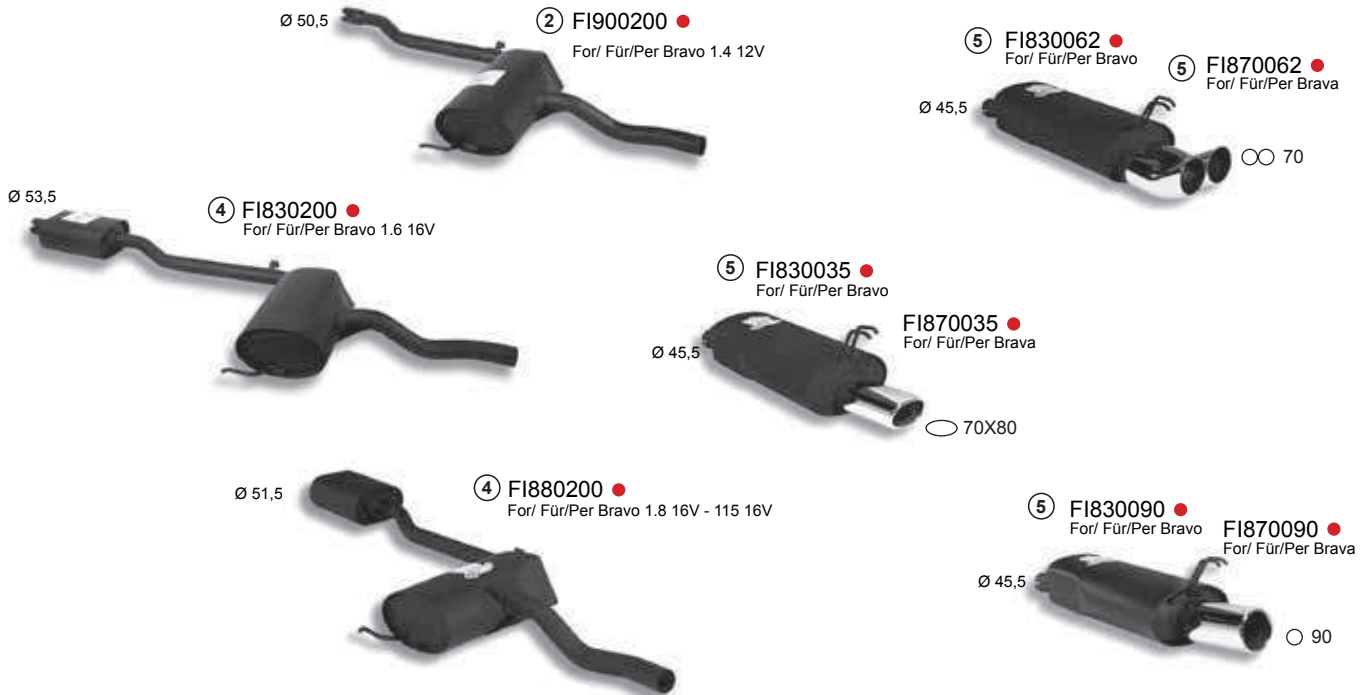
**BRAVO** 2.0 20v / HGT / 155 20v HGT

08/'95 &gt;

KIT COMPLETO - KOMPLETTESS KIT - COMPLETE KIT

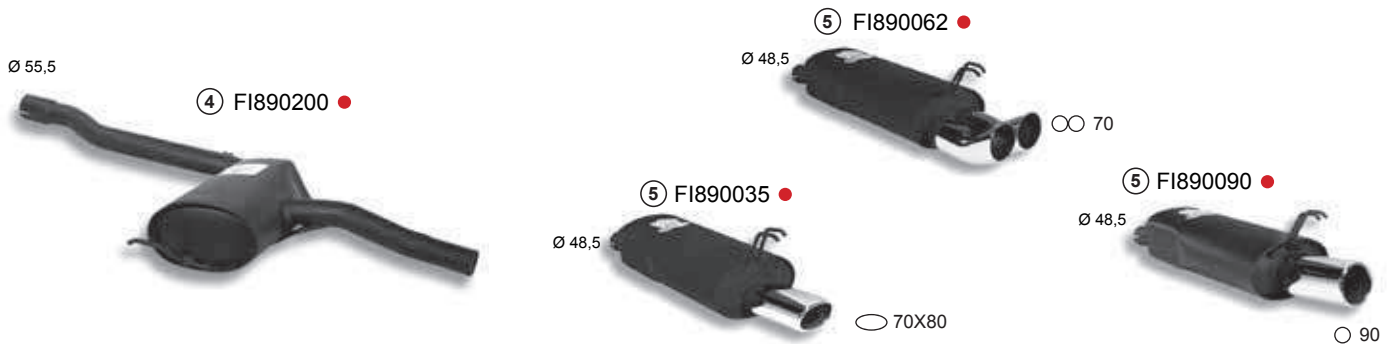
**BRAVO/BRAVA** 105 JTD

04/'98 &gt;

KIT COMPLETO - KOMPLETTESS KIT - COMPLETE KIT



(1) Collettore / Fächerkrümmer / Manifold - Down pipe

(4) Centrale / Mittelschalldämpfer / Center silencer - pipe

(2) Sport metal kat 200 cell

(5) Posteriore / Endshaldämpfer / Rear silencer - pipe

(3) Anteriore / Vorshaldämpfer / Front silencer



Sonda Lambda

**BRAVO** 1.4 T Jet - 1.4 T Jet SPORT (kW 88 - 110)

'07 >

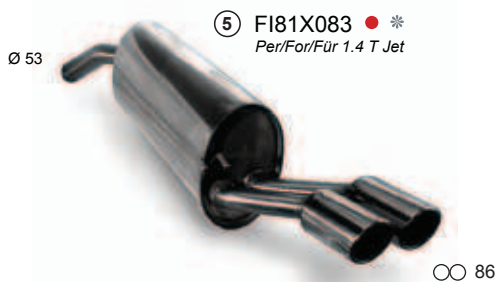

**BRAVO** 1.6 Mjet - 1.9 Mjet - 1.9 Mjet SPORT (kW 77 - 88 - 110)

'07 >



**CINQUECENTO** CAT (kW23 - 30)

03/'92 >



**CINQUECENTO** 1.1 SPORTING

09/'94 >

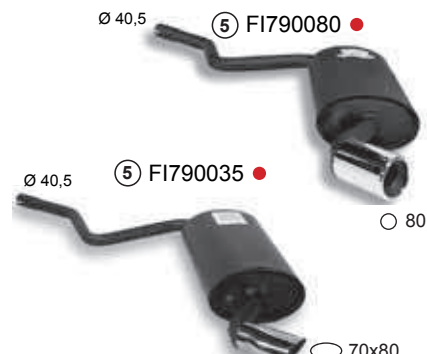

**NOTE**

Le marmitte alluminizzate hanno tutti i tubi in acciaio INOX 304  
Alle rohre der alluminierten schalldampfer bestehen aus Edestahl AISI 304  
All pipes of the alluminized exhausts are made of stainless stell AISI 304

● Omologato / EG-genehmigt - EU-approved

△ Con modifica paraurti /  
Anderung der heckschürze / Rear bumper must be cut to fit

\* Acciaio INOX AISI 304 /  
Edestahl AISI 304 / Stainless stell AISI 304

500 1.2 - 1.4 (kW 51 - 74)

07/'07 &gt;

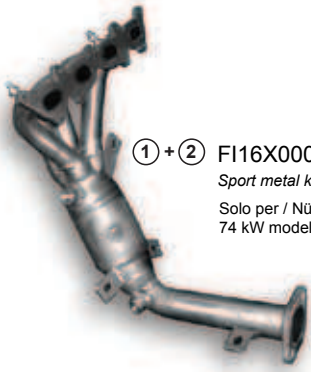

①+② FI16X000K \*

Sport metal kat 200 celle  
Solo per / Nür für / Only for  
74 kW model



④ FI16X200 \*

Solo per / Nür für / Only for  
74 kW model

⑤ FI19X120OV ● \*



146 x 75

Uscita centrale  
Centrale exit  
zentrale Abschlussprüfungen

⑤ FI19X730V ● \*



Ø 42

○○ 70x80

⑤ FI19X100V ● \*

Ø 42



○○ 120x80

⑤ FI19X2730V ● \*

Ø 42 - 47



○○ 70x80

○○ 70x80

500 1.4 TURBO - 1.4 TURBO SS (kW 99)

07/'08 &gt;



② FI36XCT00K \*

Sport metal kat 200 celle  
Per / Für / For mod. 99 kW



② FI36XCTSSK \*

Sport metal kat 200 celle  
Per / Für / For mod. SS

④ FI25X2ST ● \*



⑤ FI25X210 ● \*

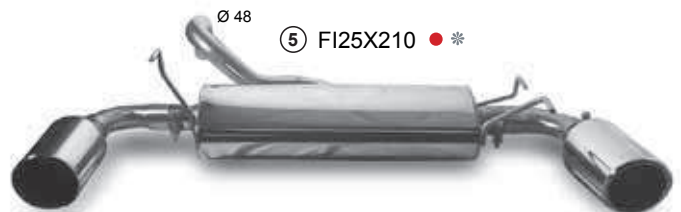

○ 100

○ 100

Ø 48

⑤ FI25X298 ● \*

○ 90  
○ 76○ 90  
○ 76

① Collettore / Fächerkrümmter / Manifold - Down pipe

④ Centrale / Mittelschalldämpfer / Center silencer - pipe

② Sport metal kat 200 cell

⑤ Posteriore / Endshaldämpfer / Rear silencer - pipe

③ Anteriore / Vorshaldämpfer / Front silencer



Sonda Lambda

500 1.3 Multijet (kW 55)

'07 >

⑤ FI24X100V ● \*



⑤ FI24X730V ● \*



COUPÉ 2.0 ie 16v

11/'93 >

KIT COMPLETO - KOMPLETTESS KIT - COMPLETE KIT

④ FI760200 ●



⑤ FI770090 ●



⑤ FI77100V ●



COUPÉ 2.0 ie 16v Turbo

11/'93 >

KIT COMPLETO - KOMPLETTESS KIT - COMPLETE KIT

④ FI770200 ●



⑤ FI770090 ●



⑤ FI77100V ●



COUPÉ 2.0 20v - 2.0 Turbo 20v

'97 >

KIT COMPLETO - KOMPLETTESS KIT - COMPLETE KIT

④ FI140200 ●



⑤ FI140090 ●



⑤ FI14100V ●



NOTE

Le marmitte alluminizzate hanno tutti i tubi in acciaio INOX 304  
 Alle rohre der alluminierten schalldampfer bestehen aus Edestahl AISI 304  
 All pipes of the alluminized exhausts are made of stainless steel AISI 304

● Omologato / EG-genehmigt - EU-approved

△ Con modifica paraurti /  
 Änderung der heckschürze / Rear bumper must be cut to fit

\* Acciaio INOX AISI 304 /  
 Edestahl AISI 304 / Stainless steel AISI 304

<b>PANDA</b> 750 - 900 - 1000	'86 >
900 IE KAT - 1.0 IE KAT	'92 >
1100	'01 >



<b>PANDA</b> 1.2 4x4 (kW 44)	10/'04 >
------------------------------	----------

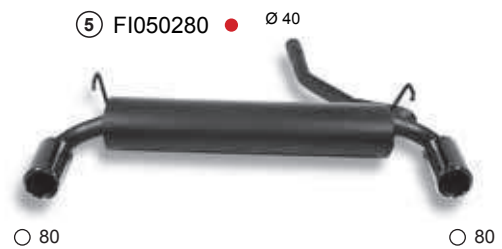
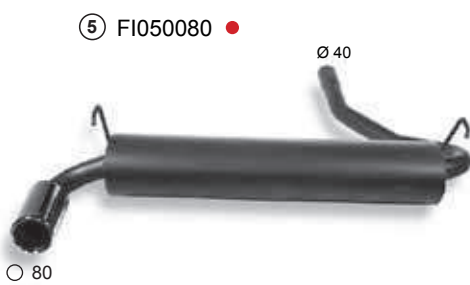

<b>PANDA</b> 1.3 Mjet (kW 51)	'05 >
-------------------------------	-------

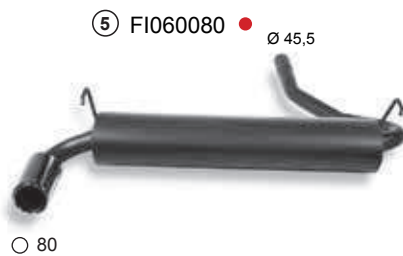

<b>PANDA</b> 1.1 - 1.2 (kW 40 - 44)	'05 >
-------------------------------------	-------



- ① Collettore / Fächerkrümmer / Manifold - Down pipe    ④ Centrale / Mittelschalldämpfer / Center silencer - pipe  
 ② Sport metal kat 200 cell    ⑤ Posteriore / Endshaldämpfer / Rear silencer - pipe  
 ③ Anteriore / Vorshaldämpfer / Front silencer



Sonda Lambda

**PANDA** 1.3 Multijet (kW 51)

'93 > '96



**PANDA** 100HP (kW 74)

'04 >



**PUNTO** 55\* - 60 / CABRIO / SELECTA / SPORTING - 75 / 85 / 90 16v

'97 >



\* KIT COMPLETO - KOMPLETTESS KIT - COMPLETE KIT per / for / für mod.55

**PUNTO** 75 EL X

09/'95 > '99

KIT COMPLETO - KOMPLETTESS KIT - COMPLETE KIT



**NOTE**  
 Le marmite alluminizzate hanno tutti i tubi in acciaio INOX 304  
 Alle rohre der alluminierten schalldämpfer bestehen aus Edestahl AISI 304  
 All pipes of the alluminized exhausts are made of stainless stell AISI 304

● Omologato / EG-genehmigt - EU-approved

△ Con modifica paraurti /  
 Änderung der heckschürze / Rear bumper must be cut to fit

\* Acciaio INOX AISI 304 /  
 Edestahl AISI 304 / Stainless stell AISI 304

## PUNTO Turbo GT (kW96)

'93 &gt; '95

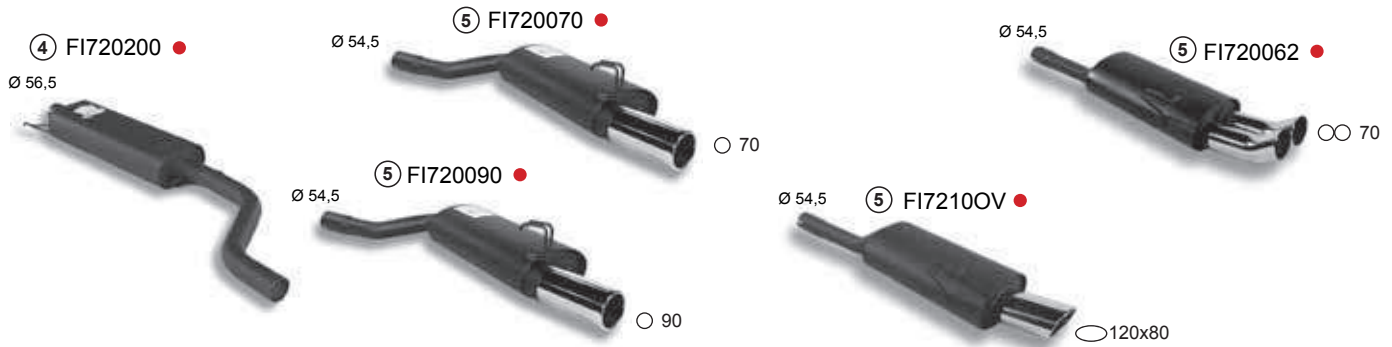

## PUNTO Turbo GT II° SERIE

'95 &gt; '99

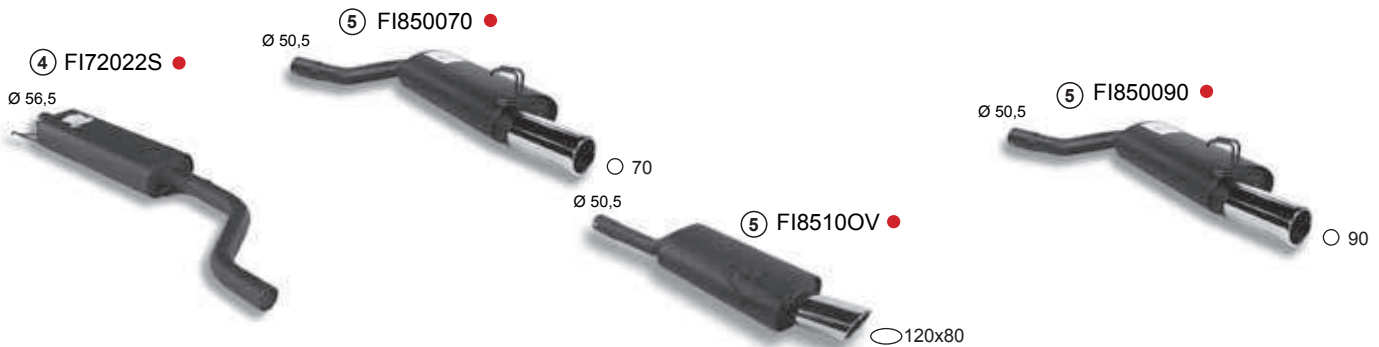

## PUNTO 1.2 8/16v - SPORTING II SERIE (kW44 - 59)

'99 &gt; '02

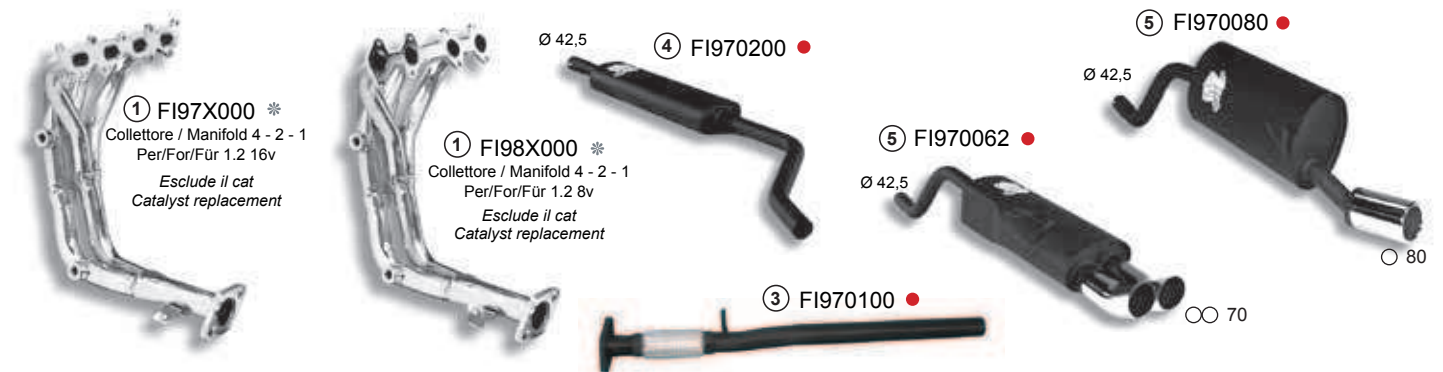

## PUNTO 1.8 16v HGT (kW 96)

09/'99 &gt;

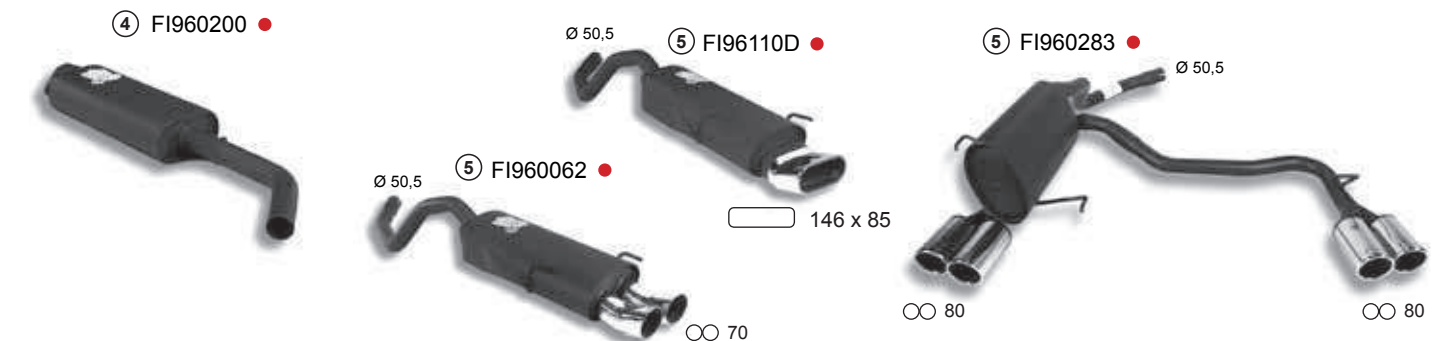

① Collettore / Fächerkrümmer / Manifold - Down pipe

④ Centrale / Mittelschalldämpfer / Center silencer - pipe

② Sport metal kat 200 cell

⑤ Posteriore / Endshalldämpfer / Rear silencer - pipe

③ Anteriore / Vorshalldämpfer / Front silencer



Sonda Lambda

**PUNTO** 1.9 JTD 3 Porte (kW 59)

09/'99 >



**GRANDE PUNTO** 1.2 - 1.4 8/16v (kW 48 - 57 - 70)

'05 >

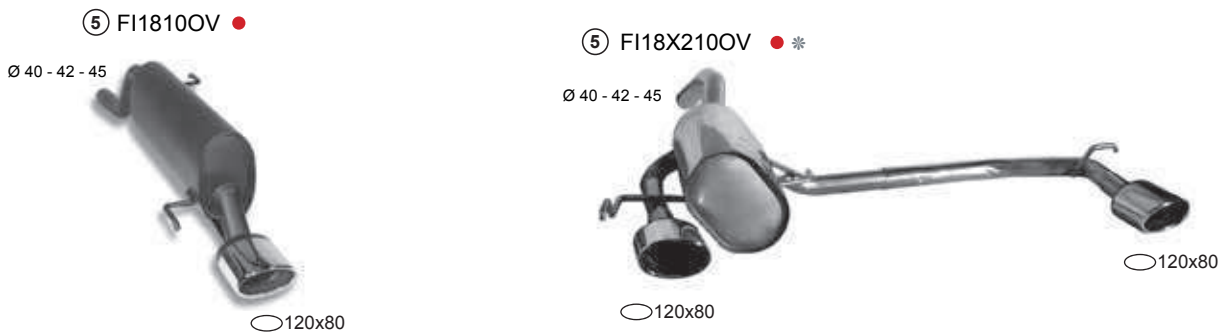

**GRANDE PUNTO** 1.4 TURBO (kW 88)

'05 >



**GRANDE PUNTO** ABARTH 1.4 Turbo / Evo / SS (kW 114 - 132)

'08 >

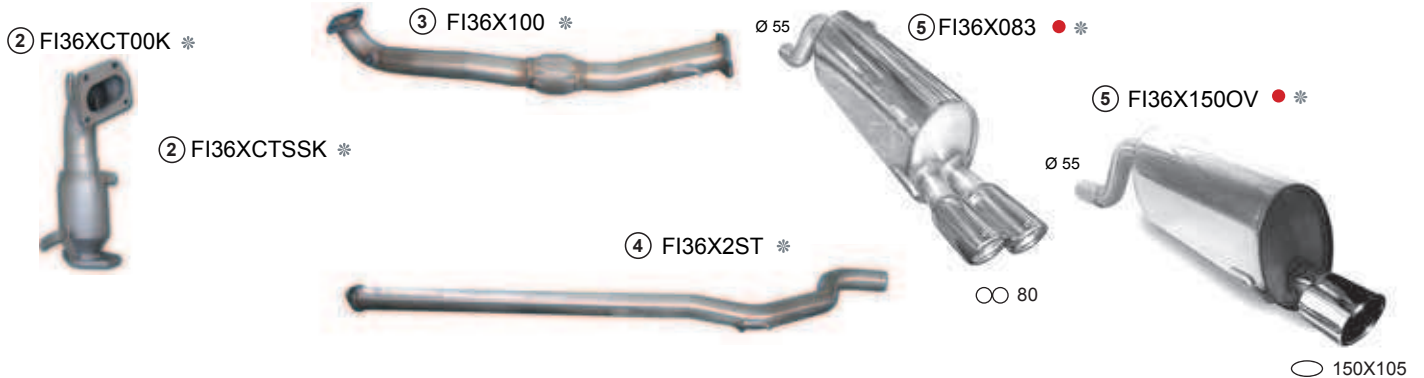

**NOTE**

Le marmitte alluminizzate hanno tutti i tubi in acciaio INOX 304  
 Alle rohre der alluminierten schalldampfer bestehen aus Edestahl AISI 304  
 All pipes of the alluminized exhausts are made of stainless steel AISI 304

● Omologato / EG-genehmigt - EU-approved

△ Con modifica paraurti /  
 Änderung der heckschürze / Rear bumper must be cut to fit

\* Acciaio INOX AISI 304 /  
 Edelstahl AISI 304 / Stainless steel AISI 304

**GRANDE PUNTO** 1.3 - 1.9 JTD SPORT (kW 55 - 66 - 88 - 96) '05 >

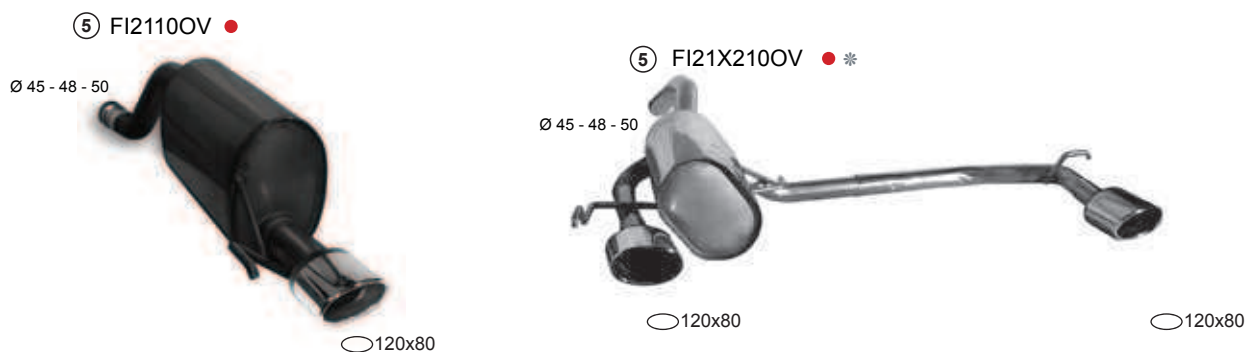

**GRANDE PUNTO** EVO 1.4 Multiair Sport 10/'09 >

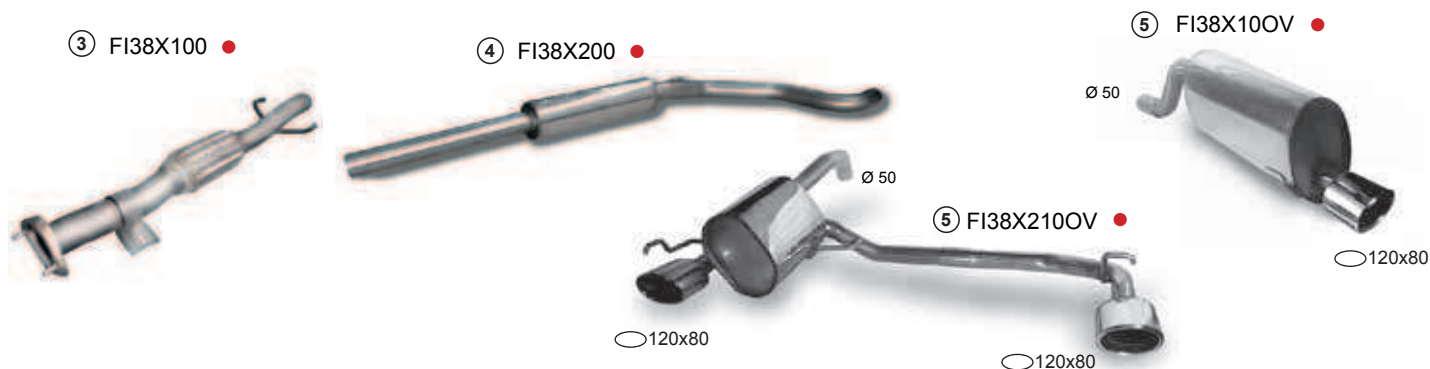

**SEICENTO** 900 (kW 29) 04/'98 >



**SEICENTO** 1.1 SPORTING (kW 40) 04/'98 > '01



- ① Collettore / Fächerkrümmer / Manifold - Down pipe
- ② Sport metal kat 200 cell
- ③ Anteriore / Vorshalldämpfer / Front silencer
- ④ Centrale / Mittelschalldämpfer / Center silencer - pipe
- ⑤ Posteriore / Endshalldämpfer / Rear silencer - pipe



Sonda Lambda

**STILO** 1.6 16v - 1.8 16v 3 porte (kW 76 - 98)

'01 >



**SEDICI** 1.6i (kW 79)

03/'06 >



**SEDICI** 1.9 Multijet (kW 88)

03/'06 >



**NOTE**

Le marmitte alluminizzate hanno tutti i tubi in acciaio INOX 304  
 Alle rohre der alluminierten schalldämpfer bestehen aus Edestahl AISI 304  
 All pipes of the alluminized exhausts are made of stainless steel AISI 304

● Omologato / EG-genehmigt - EU-approved

△ Con modifica paraurti /  
 Änderung der heckschürze / Rear bumper must be cut to fit

\* Acciaio INOX AISI 304 /  
 Edelstahl AISI 304 / Stainless steel AISI 304

## FIESTA 1.2 16v - 1.3 (kW 55 - 44)

09/'95 &gt; 10/'01



## FIESTA 1.4 16v (kW 66)

05/'95 &gt; 10/'01



## FIESTA ST 150 (kW 110)

'05 &gt;



## FIESTA 1.2 (kW 44)

09/'08 &gt;

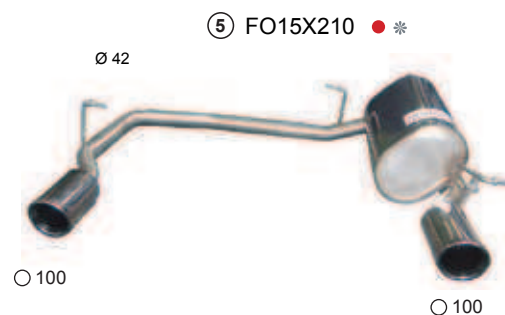
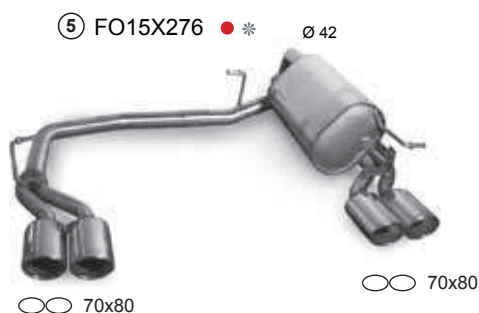

① Collettore / Fächerkrümmer / Manifold - Down pipe

④ Centrale / Mittelschalldämpfer / Center silencer - pipe

② Sport metal kat 200 cell

⑤ Posteriore / Endshaldämpfer / Rear silencer - pipe

③ Anteriore / Vorshaldämpfer / Front silencer



Sonda Lambda

**FIESTA MK7** 1.4 - 1.6 (kW 71 - 88)

09/'08 >

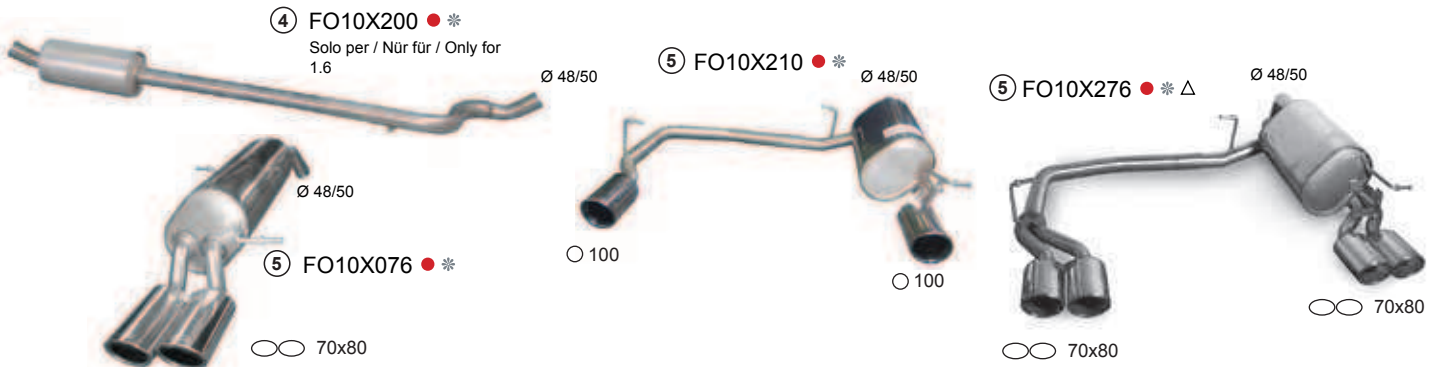

**FIESTA MK7** 1.4 - 1.6 TDCI (kW 50 - 66)

09/'08 >

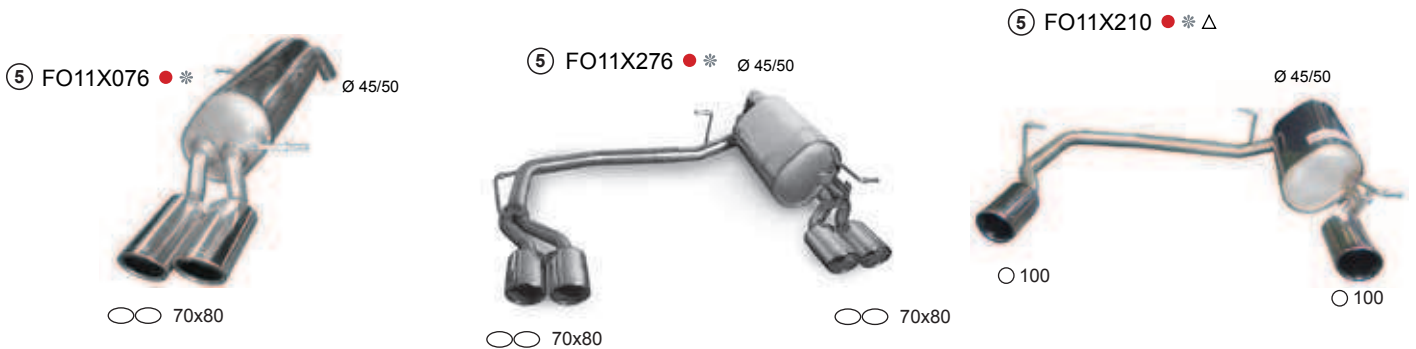

**FIESTA** 1.6 (kW 99)

2011 >



**FOCUS** 1.6 16v 3/5 porte (kW 74)

10/'98 > '04

1.6 16v SW (kW 74)

10/'98 > '04



**NOTE**

Le marmitte alluminizzate hanno tutti i tubi in acciaio INOX 304  
Alle rohre der alluminierten schalldampfer bestehen aus Edestahl AISI 304  
All pipes of the alluminized exhausts are made of stainless stell AISI 304

● Omologato / EG-genehmigt - EU-approved

Δ Con modifica paraurti /  
Anderung der heckschürze / Rear bumper must be cut to fit

\* Acciaio INOX AISI 304 /  
Edestahl AISI 304 / Stainless stell AISI 304

**FOCUS** 1.8 16v 3/5 Porte - 2.0 16v 3/5 Porte (kW 74) 10/'98 > '04  
 1.8 16v SW - 2.0 16V SW (kW 74) 10/'98 > '04

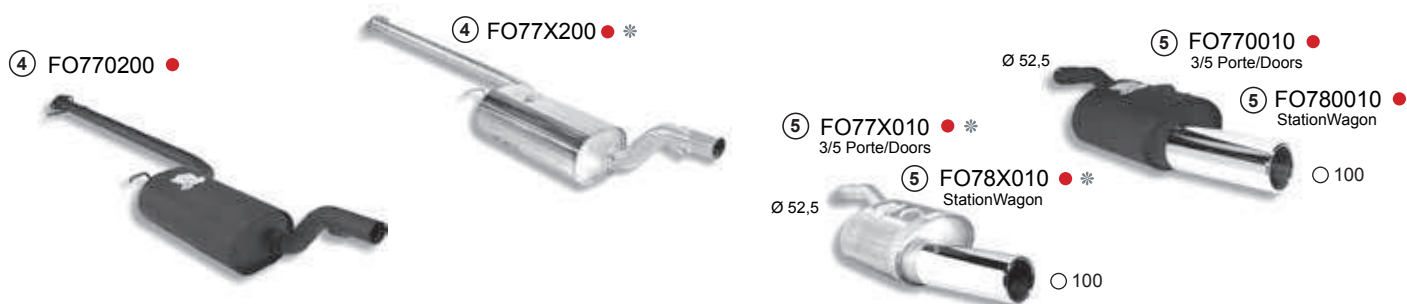

**FOCUS** 1.8 16v 3/5 Porte - 2.0 16v 3/5 Porte 10/'98 > '04  
 MAGGIORATO Ø 60 - KIT COMPLETO



**FOCUS** 2.0 ST 170 6M 3/5 Porte 10/'98 > '04  
 2.0 ST 170 6M SW

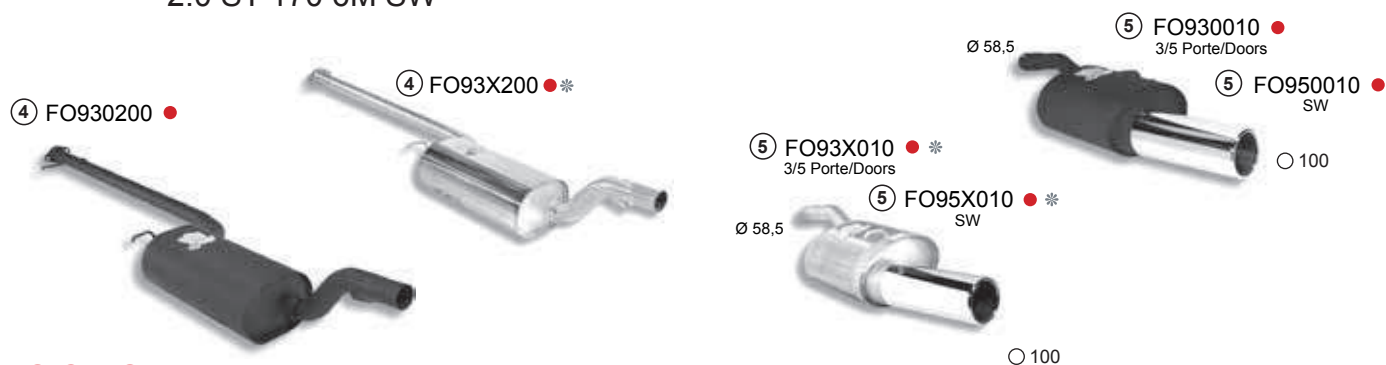

**FOCUS** RS 2.0 3 Porte  
 MAGGIORATO Ø 70 KIT COMPLETO - OVERSIZE EXHAUST SISTEM Ø 70 COMPLETE KIT



- ① Collettore / Fächerkrümmer / Manifold - Down pipe  
 ② Sport metal kat 200 cell  
 ③ Anteriore / Vorshaldämpfer / Front silencer  
 ④ Centrale / Mittelschalldämpfer / Center silencer - pipe  
 ⑤ Posteriore / Endshaldämpfer / Rear silencer - pipe



Sonda Lambda

## FOCUS 1.8 TDDI 1° SERIE (kW 66)

10/'98 > 11/'99

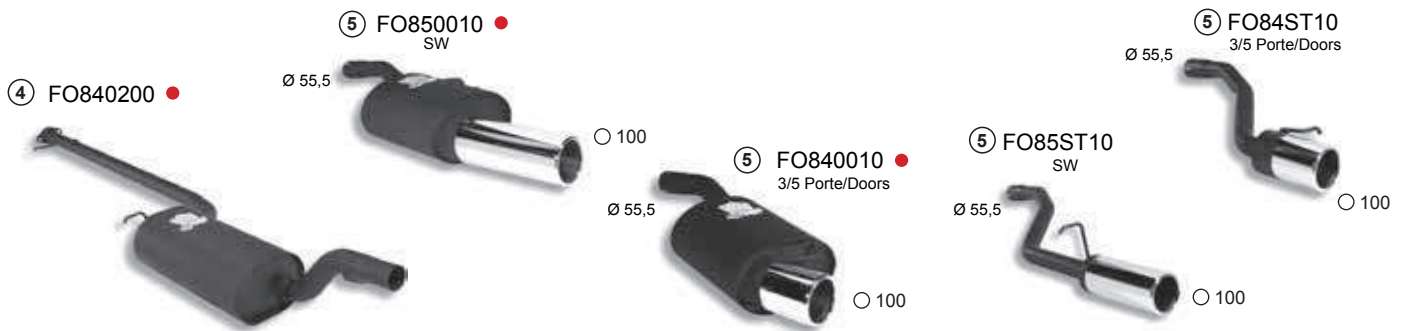

## FOCUS 1.8 TDDI 2° SERIE (kW 85)

06/'01 >

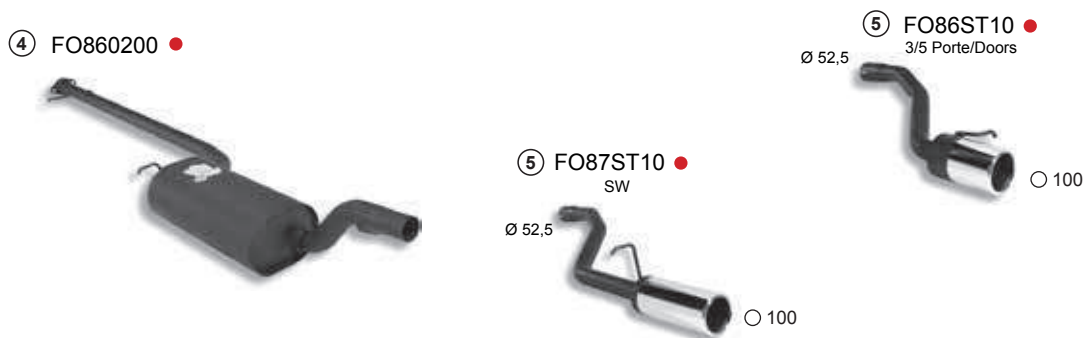

## FOCUS ST 225 2.5 Turbo (kW 165)

'05 >



## FOCUS RS 500 2.5 i Turbo - RS2.5 TURBO (kW 225 - 257)

'09 >

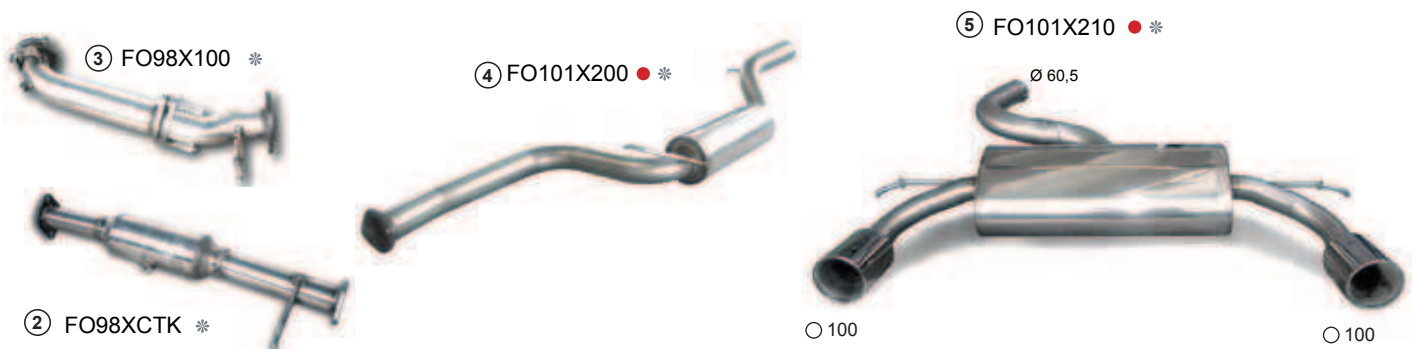

### NOTE

Le marmitte alluminizzate hanno tutti i tubi in acciaio INOX 304  
 Alle rohre der alluminierten schalldampfer bestehen aus Edestahl AISI 304  
 All pipes of the alluminized exhausts are made of stainless steel AISI 304

● Omologato / EG-genehmigt - EU-approved

△ Con modifica paraurti /  
 Änderung der heckschürze / Rear bumper must be cut to fit

\* Acciaio INOX AISI 304 /  
 Edestahl AISI 304 / Stainless steel AISI 304

**FOCUS** 1.6 (kW 110)

2011 &gt;

⑤ FO13X100V ● \*

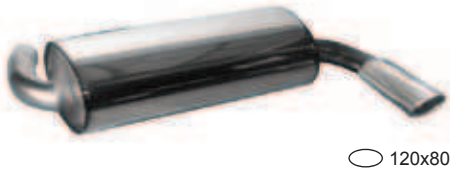

○ 120x80

⑤ FO13X2100V ● \*

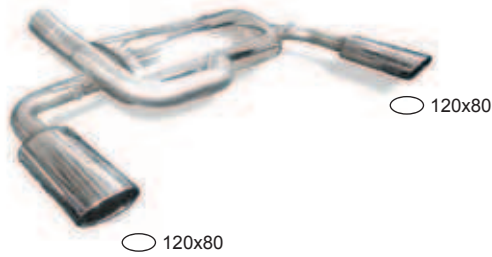

○ 120x80

○ 120x80

**C-MAX** 1.6 SCTI (kW 110)

11/'10 &gt;

⑤ FO12X100V ● \*

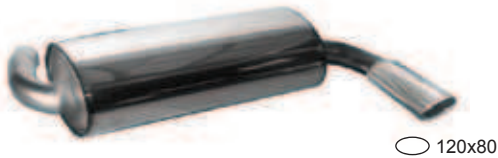

○ 120x80

⑤ FO12X2100V ● \*



○ 120x80

○ 120x80

**PUMA** 1.4i 16v (kW 66)

'97 &gt; 12/'01

④ FO720200 ●

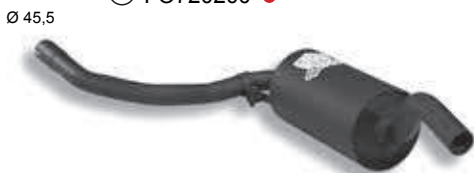

Ø 45,5

⑤ FO740090 ●



Ø 45,5

○ 90

⑤ FO740035 ●



Ø 45,5

○ 70x80

**PUMA** 1.6 16v - 1.7i 16v (kW 76 - 92)

06/'97 &gt; 12/'01

④ FO740200 ●



Ø 50,5

⑤ FO740090 ●



Ø 50,5

○ 90

⑤ FO740035 ●



Ø 50,5

○ 70x80

① Collettore / Fächerkrümmer / Manifold - Down pipe

④ Centrale / Mittelschalldämpfer / Center silencer - pipe

② Sport metal kat 200 cell

⑤ Posteriore / Endshalldämpfer / Rear silencer - pipe

③ Anteriore / Vorshalldämpfer / Front silencer



Sonda Lambda

KA 1.3

'96 >



⑤ FO730090 ●

KA 1.2 (kW 51)

09/'08 >

⑤ FO19X100V ● \*



⑤ FO19X730V ● \*



⑤ FO19X2730V ● \*



KUGA 2.0 TDCi (kW 100)

06/'08 >

⑤ FO99X210 ● \*



KUGA 2.5 Turbo (kW 147)

06/'08 >

② FO100XCTK \*  
Sport Kat 200 celle / 200 zellen / 200 cell

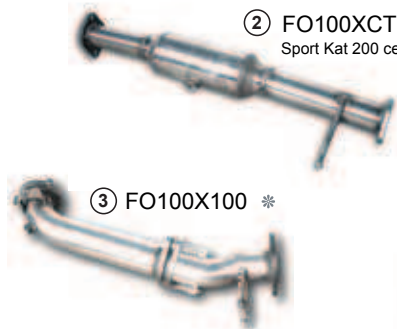

③ FO100X100 \*



④ FO100X200 ● \*



⑤ FO100X210 ● \*



NOTE

Le marmitte alluminizzate hanno tutti i tubi in acciaio INOX 304  
Alle rohre der alluminierten schalldämpfer bestehen aus Edestahl AISI 304  
All pipes of the alluminized exhausts are made of stainless steel AISI 304

● Omologato / EG-genehmigt - EU-approved

△ Con modifica paraurti /  
Anderung der heckschürze / Rear bumper must be cut to fit

\* Acciaio INOX AISI 304 /  
Edelstahl AISI 304 / Stainless steel AISI 304

<b>CIVIC</b>	3 Porte 1.3/1.5/1.6 ESI - 1.6 VTI (kW 92 - 118)	'95 >
	3 Porte 1.4/1.5 V TEC - 1.6 VTI (kW 84 - 118)	'96 >



④ HN030200 ●



⑤ HN030080 ●

○ 80

<b>CIVIC</b>	3 Porte 1.4/1.6 V TEC SPORT	02/'01 > 09/'05
--------------	-----------------------------	-----------------

④ HN04X200 ● \*



⑤ HN04X083 ● \*



○○ 80

⑤ HN04X110 ● \*



□ 145 x 75

<b>CIVIC</b>	2.0 V TEC TYPE R	11/'03 >
--------------	------------------	----------

HN05X200 ● \*



⑤ HN05X083 ● \*



○○ 80

⑤ HN05X110 ● \*



□ 145 x 75

<b>S 2000</b>		04/'04 > 04/'06
---------------	--	-----------------

KIT COMPLETO - COMPLETE KIT

④ HN06X200 ● \*



⑤ HN06XS151 ● \*



○ 145x105

⑤ HN06XD151 ● \*



○ 145x105

① Collettore / Fächerkrümmer / Manifold - Down pipe

④ Centrale / Mittelschalldämpfer / Center silencer - pipe

② Sport metal kat 200 cell

⑤ Posteriore / Endschalldämpfer / Rear silencer - pipe

③ Anteriore / Vorshalldämpfer / Front silencer



Sonda Lambda

<b>CR-V</b> 2.0i (kW 110)	'06 >
2.2 CDTI (kW 103)	'06 >

⑤ HN07X010 ● \* Per / Für / For 2.0i

⑤ HN08X010 ● \* Per / Für / For 2.0 CDTI



<b>JAZZ</b> 1.2 - 1.4i (kW 57 - 61)	'02 > '08
-------------------------------------	-----------

⑤ HN09X083 ● \*



<b>JAZZ</b> 1.2 - 1.4i (kW 66 - 73)	'08 >
-------------------------------------	-------

⑤ HN10X083 ● \*



**NOTE**

Le marmitte alluminate hanno tutti i tubi in acciaio INOX 304  
 Alle rohre der alluminierten schalldampfer bestehen aus Edestahl AISI 304  
 All pipes of the alluminized exhausts are made of stainless stell AISI 304

● Omologato / EG-genehmigt - EU-approved

△ Con modifica paraurti /  
 Änderung der heckschürze / Rear bumper must be cut to fit

\* Acciaio INOX AISI 304 /  
 Edelstahl AISI 304 / Stainless stell AISI 304

**COUPE' TIBURON** 1.6 16v - 2.0 16v (kW 85 - 102) '96 > '99

**COUPE' TIBURON** 1.6 16v - 2.0 16v (kW 85 - 102) '99 >

**TUCSON** 2.0 16v (kW 104) '99 >

## 2.0 CRDI - 2.7i (kW 103 - 129) '99 &gt;

⑤ HD05X280 ● \* △ Solo per / Nür für / Only for 2.0 16v

⑤ HN06X280 ● \* △ Solo per / Nür für / Only for 2.0 CRDI - 2.7i

**i20** 1.2 - 1.4 - 1.6 (kW 57 - 74) 02/'09 >

⑤ HD07X076OV ● \* Per / Für / For 1.2 - 1.4

⑤ HD08X076OV ● \* Per / Für / For 1.6



① Collettore / Fächerkrümmer / Manifold - Down pipe

④ Centrale / Mittelschalldämpfer / Center silencer - pipe

② Sport metal kat 200 cell

⑤ Posteriore / Endshalldämpfer / Rear silencer - pipe

③ Anteriore / Vorshalldämpfer / Front silencer



Sonda Lambda

VELOSTER 1.6 (kW 103)

09/'11 &gt;

⑤ HD09X3760V ● \*



○○○ 70x80

*IN PREPARAZIONE / IN VORBEREITUNG / AVAIBLE SOON*

**NOTE**

Le marmite alluminate hanno tutti i tubi in acciaio INOX 304  
 Alle rohre der alluminierten schalldampfer bestehen aus Edestahl AISI 304  
 All pipes of the alluminized exhausts are made of stainless stell AISI 304

● Omologato / EG-genehmigt - EU-approved

△ Con modifica paraurti /  
 Änderung der heckschürze / Rear bumper must be cut to fit

\* Acciaio INOX AISI 304 /  
 Edelstahl AISI 304 / Stainless stell AISI 304

<b>SPORTAGE</b>	2.0 16v (kW 104)	'05 >
	2.0 CRD - 2.7i (kW 103 - 129)	'05 >

⑤ KI01X280 ● \* Per / Für / For 2.0 16v

⑤ KI02X280 ● \* Per / Für / For 2.0 CRD - 2.7i



∅ 76

∅ 76

- ① Collettore / Fächerkrümmer / Manifold - Down pipe    ④ Centrale / Mittelschalldämpfer / Center silencer - pipe  
 ② Sport metal kat 200 cell    ⑤ Posteriore / Endshalldämpfer / Rear silencer - pipe  
 ③ Anteriore / Vorshalldämpfer / Front silencer



Sonda Lambda

**BETA BERLINA COUPÉ HPE** 1.6 - 1.8 - 2.0  
**TREVI** 1.6 - 2.0



① LA050000 \*  
 Collettore / Fächerkrümmer / Manifold 4-2-1

**BETA MONTECARLO** 2.0 '75 > '85

KIT COMPLETO - KOMPLETTESS KIT - COMPLETE KIT



① + ⑤ LA070000  
 Collettore / Fächerkrümmer / Manifold 4-2-1

LA070031

**DEDRA** 2.0 ie Turbo (kW 120) '91 > '92

KIT COMPLETO - KOMPLETTESS KIT - COMPLETE KIT



④ LA310200 ●

Ø 57,5



⑤ LA250080 ●

Ø 60,5

○ 80

**DEDRA** 2.0 ie Turbo Cat (kW 130) '91 > '92

KIT COMPLETO - KOMPLETTESS KIT - COMPLETE KIT



④ LA250200 ●



⑤ LA250080 ●

Ø 60,5

○ 80

**NOTE**

Le marmitte alluminizzate hanno tutti i tubi in acciaio INOX 304  
 Alle rohre der alluminierten schalldämpfer bestehen aus Edestahl AISI 304  
 All pipes of the alluminized exhausts are made of stainless stell AISI 304

● Omologato / EG-genehmigt - EU-approved

△ Con modifica paraurti /  
 Änderung der heckschürze / Rear bumper must be cut to fit

\* Acciaio INOX AISI 304 /  
 Edestahl AISI 304 / Stainless stell AISI 304

**DEDRA** 2.0 ie Turbo INTEGRALE (kW 130)

08/'91 &gt; '92

④ LA270200 ●



⑤ LA270035 ●

**DELTA** 1.6 ie HF Turbo (kW 103)

05/'86 &gt; '92

Ø 52,5

④ LA300200 ●

Per / Für / For 1.6 ie HF Turbo 103 kW



⑤ LA150080 ●



○ 80

**DELTA** 2.0 HF 4WD - 2.0 HF INTEGRALE 8v/16v

05/'86 &gt; '90

③ LA200100



Ø 54,5

④ LA200200



⑤ LA200032



○ 60

① LA200000



○ 60

**DELTA** 2.0 HF 4WD - 2.0 HF INTEGRALE 8v/16v

05/'86 &gt; '90

MAGGIORATO Ø 60 KIT COMPLETO - OVERSIZE EXHAUST SYSTEM Ø 60 COMPLETE KIT

③ LA210100



Ø 60,5

④ LA210200



⑤ LA210082



○ 80

① LA200000



○ 80

① Collettore / Fächerkrümmer / Manifold - Down pipe

④ Centrale / Mittelschalldämpfer / Center silencer - pipe

② Sport metal kat 200 cell

⑤ Posteriore / Endshalldämpfer / Rear silencer - pipe



Sonda Lambda

③ Anteriore / Vorshalldämpfer / Front silencer

## DELTA 2.0 HF INTEGRALE EVOLUZIONE 8v/16v

'91 > '94



## DELTA II 2.0 ie Turbo 16v - HPE

03/'93 >

KIT COMPLETO - KOMPLETTES KIT - COMPLETE KIT



## DELTA 1.4 T-JET (kW 88-110)

'08 >



## DELTA 1.6 M/Jet / 1.9 Twinturbo (kW 121 - 140)

'08 >

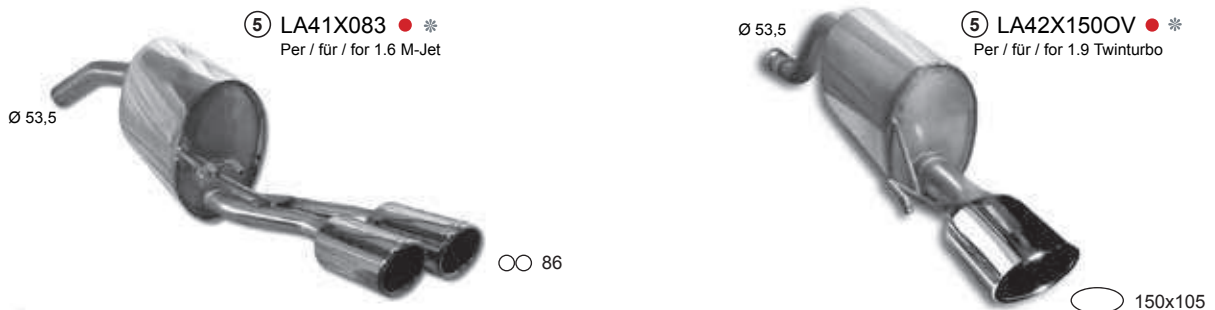

### NOTE

Le marmite alluminate hanno tutti i tubi in acciaio INOX 304  
Alle rohre der alluminierten schalldampfer bestehen aus Edestahl AISI 304  
All pipes of the alluminized exhausts are made of stainless stell AISI 304

● Omologato / EG-genehmigt - EU-approved

△ Con modifica paraurti /  
Änderung der heckschürze / Rear bumper must be cut to fit

\* Acciaio INOX AISI 304 /  
Edelstahl AISI 304 / Stainless stell AISI 304

## FULVIA COUPÉ 1.3 5M - 1.6 HF CUOPÉ MONTECARLO

'70 &gt; '76

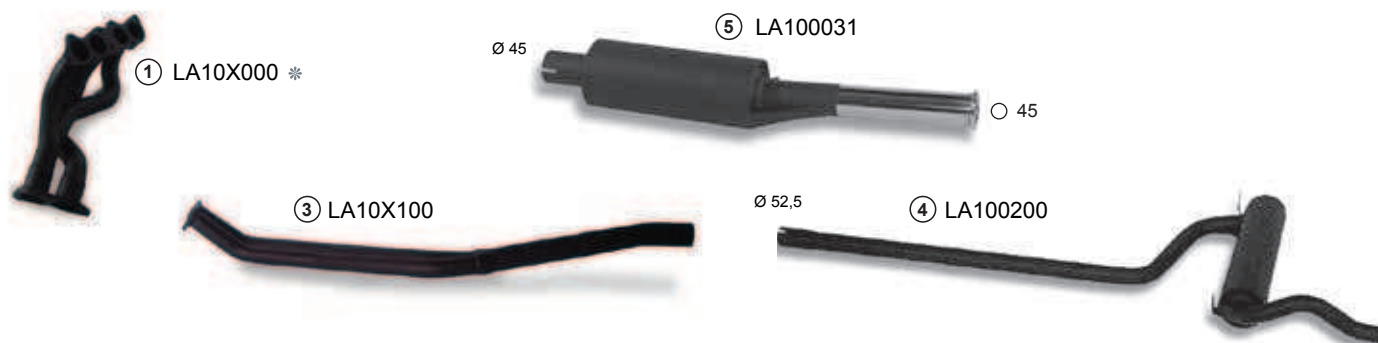

## Y 1.1 8/16v - 1.2 8/16v - 1.4 8/16v (kW 40 - 44 - 59 - 63)

'96 &gt; '00



## Y 1.2 16v

10/'00 &gt; 07/'03



- ① Collettore / Fächerkrümmer / Manifold - Down pipe  
 ② Sport metal kat 200 cell  
 ③ Anteriore / Vorshaldämpfer / Front silencer  
 ④ Centrale / Mittelschalldämpfer / Center silencer - pipe  
 ⑤ Posteriore / Endshaldämpfer / Rear silencer - pipe



Sonda Lambda

## LAND ROVER

**FREELANDER 2** 2.2 TD 4 - 2.7 D (kW 118 - 140)

'06 >

⑤ LD01X2150V ● \*



□ 145 x 75

□ 145 x 75

⑤ LD01X2730V ● \*



○ 70x80

○ 70x80

## MASERATI

**4.2 COUPÉ GT 6M**

'02 >

⑤ MS01XS730V \*



○ 70x80

⑤ MS01XD730V \*



○ 70x80

**NOTE**

Le marmitte alluminate hanno tutti i tubi in acciaio INOX 304  
 Alle rohre der alluminierten schalldampfer bestehen aus Edestahl AISI 304  
 All pipes of the alluminized exhausts are made of stainless stell AISI 304

● Omologato / EG-genehmigt - EU-approved

△ Con modifica paraurti /  
 Aenderung der heckschürze / Rear bumper must be cut to fit

\* Acciaio INOX AISI 304 /  
 Edelstahl AISI 304 / Stainless stell AISI 304

## 121 1.2i 16v - 1.3i

'96 &gt;



## 121 1.8 D

'96 &gt;



## MX 5 1.6 16v COUPÉ

04/'90 &gt; 12/'93

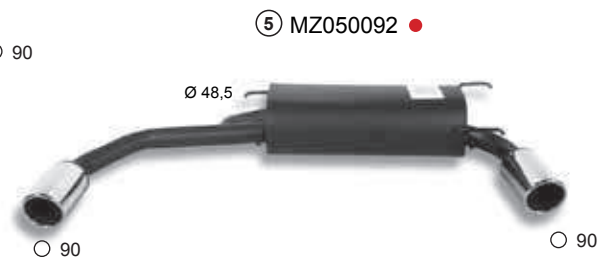
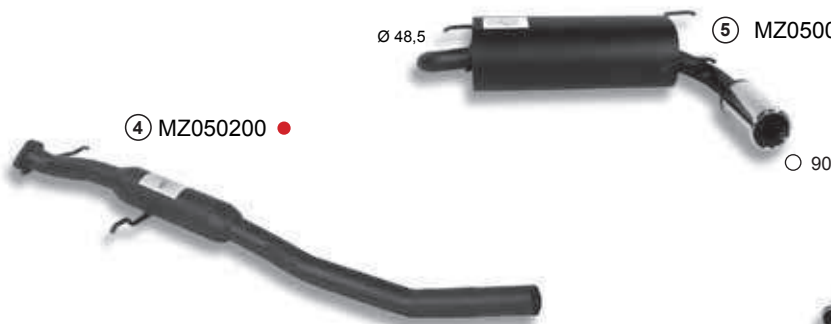

## RX 8 1.3 (kW 170)

'03 &gt;

KIT COMPLETO - KOMPLETTESS KIT - COMPLETE KIT



① Collettore / Fächerkrümmer / Manifold - Down pipe

④ Centrale / Mittelschalldämpfer / Center silencer - pipe

② Sport metal kat 200 cell

⑤ Posteriore / Endshalldämpfer / Rear silencer - pipe

③ Anteriore / Vorshalldämpfer / Front silencer



Sonda Lambda

**COUPER S** 1.6 16v (kW 120 - 125)

'02 &gt; '06



① **BM33X00K**  
Collettore / Fächerkrümmer / Manifold 4-2-1  
*Sport metal kat 200 celle*

⑤ **BM33X083** ●



∅ 80

**COUPER S** 1.6 Turbo R56 (kW 128 - 135)

'07 &gt;

② **BM36X100K** \*

Sport Kat 200 celle  
200 zellen / 200 cell  
*IN PREPARAZIONE  
IN VORBEREITUNG  
AVAILABLE SOON*



④ **BM36X200** ● \*



⑤ **BM36X083** ● \*



∅ 86

**NOTE**

Le marmitte alluminate hanno tutti i tubi in acciaio INOX 304  
Alle rohre der alluminierten schalldämpfer bestehen aus Edestahl AISI 304  
All pipes of the alluminized exhausts are made of stainless stell AISI 304

● Omologato / EG-genehmigt - EU-approved

△ Con modifica paraurti /  
Anderung der heckschürze / Rear bumper must be cut to fit

\* Acciaio INOX AISI 304 /  
Edelstahl AISI 304 / Stainless stell AISI 304

**QASHQAI** 1.6 16v - 1.5 dCi (kW 84 - 78)

'07 &gt;

NS08X2110 ● \*

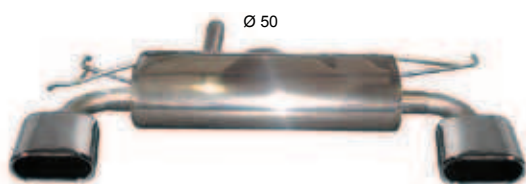

□ 125 x 65

□ 125 x 65

NS08X2730V ● \*

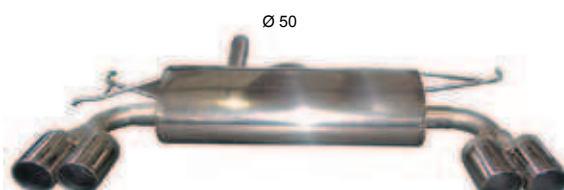

○ 70X80

○ 70X80

**QASHQAI** 2.0 dCi - 2.0 16v (kW 104 - 110)

'07 &gt;

NS09X2110 ● \*

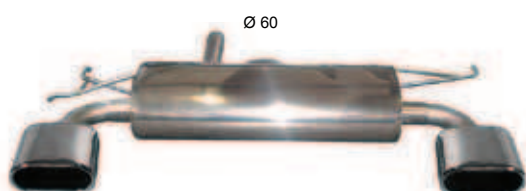

□ 125 x 65

□ 125 x 65

NS09X2730V ● \*

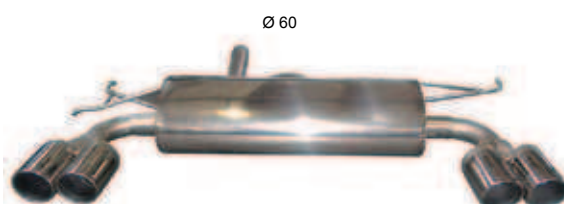

○ 70X80

○ 70X80

**350 Z** Coupé 3.5 V6 - Roadstar 3.5 V6 (kW 230)

'07 &gt;

NS10X210 ● \*



○ 100

○ 100

- ① Collettore / Fächerkrümmer / Manifold - Down pipe
- ② Sport metal kat 200 cell
- ③ Anteriore / Vorshaldämpfer / Front silencer
- ④ Centrale / Mittelschalldämpfer / Center silencer - pipe
- ⑤ Posteriore / Endshaldämpfer / Rear silencer - pipe



Sonda Lambda

**ASTRA** 2.0 16v GSI Cat. (kW 85)

'91 >



**ASTRA G** 1.4 16v 3/5 porte/doors - 1.6 8v/16v 3/5 porte/doors

05/'98 >

1.8 16v 3/5 porte/doors - 2.0 16v 3/5 porte/doors

'98 >

1.4 16v SW - 1.6 8v/16v SW

'98 >

1.8 16v SW - 2.0 16v SW

'98 >

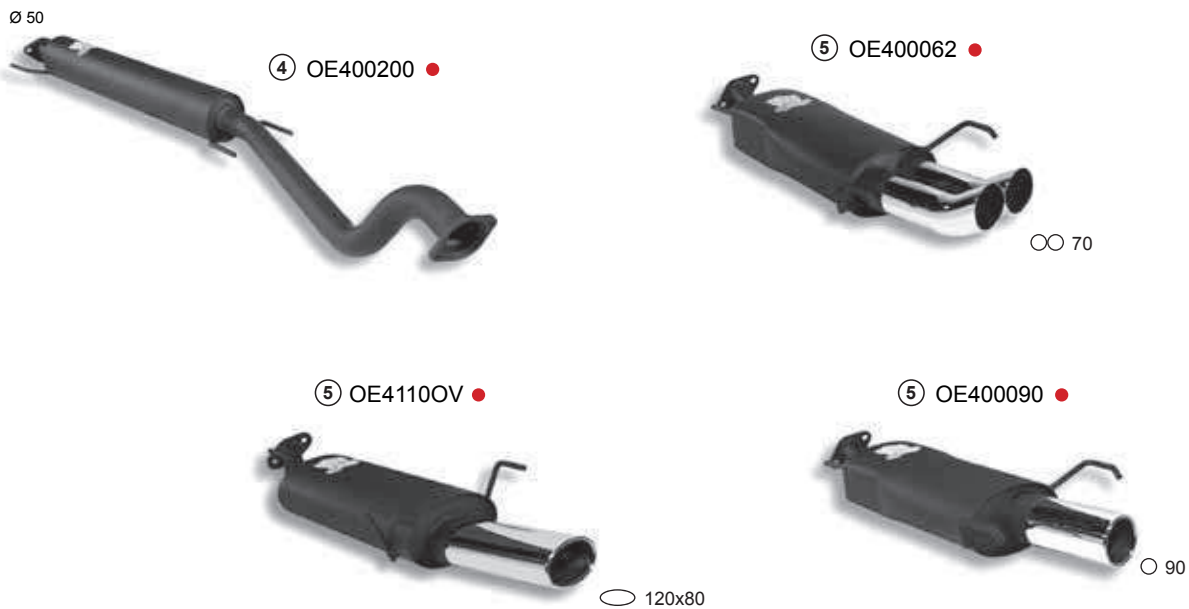

**ASTRA G** 1.8 16v Coupé

05/'98 >



**NOTE**

Le marmitte alluminate hanno tutti i tubi in acciaio INOX 304  
 Alle rohre der alluminierten schalldampfer bestehen aus Edestahl AISI 304  
 All pipes of the alluminized exhausts are made of stainless stell AISI 304

● Omologato / EG-genehmigt - EU-approved

△ Con modifica paraurti /  
 Änderung der heckschürze / Rear bumper must be cut to fit

\* Acciaio INOX AISI 304 /  
 Edelstahl AISI 304 / Stainless stell AISI 304

**ASTRA G** 2.0 16v Coupé Turbo

10/'00 &gt;

**ASTRA G** 2.0 i OPC (kW 118)

10/'00 &gt;

**ASTRA J** 1.4 / 1.6 16V COSMO / ELECTIVE (kW 74 - 85)

'11/2010 &gt;

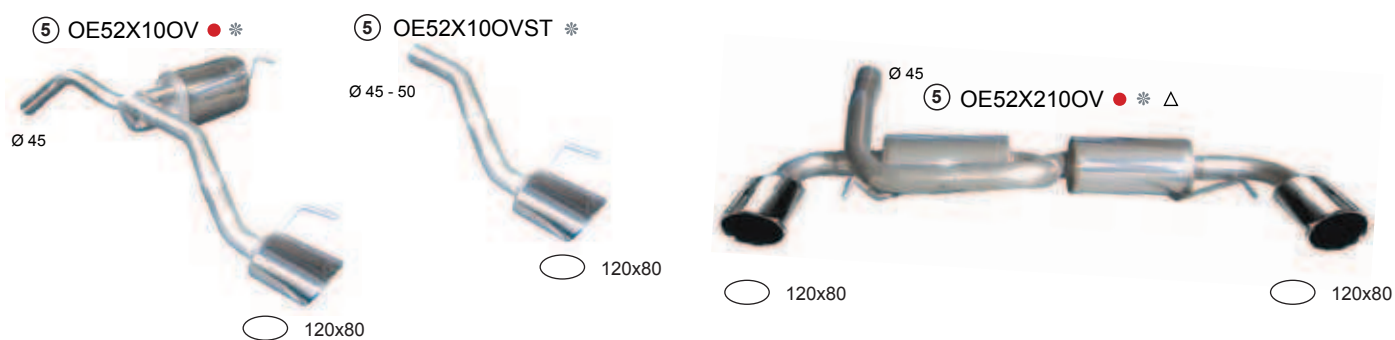
**ASTRA** 1.6 Turbo Cosmo S (kW 132)

'11/2010 &gt;



① Collettore / Fächerkrümmer / Manifold - Down pipe

④ Centrale / Mittelschalldämpfer / Center silencer - pipe

② Sport metal kat 200 cell

⑤ Posteriore / Endshalldämpfer / Rear silencer - pipe

③ Anteriore / Vorshalldämpfer / Front silencer



Sonda Lambda

**ASTRA J** J 1.3 CDTI DPF ECOFLEX COSMO / ELECTIVE (kW 70) '11/2010 >

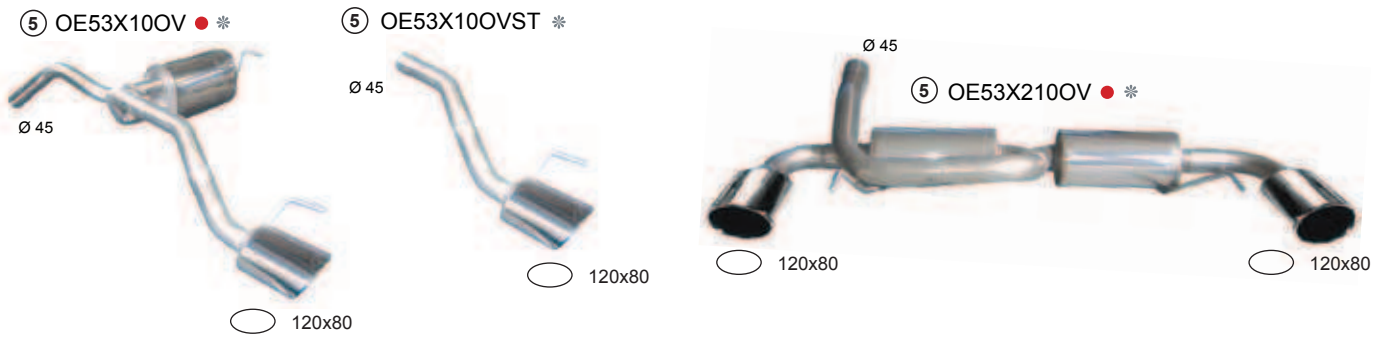

**ASTRA** 1.7 CDTI DPF COSMO / ELECTIVE (kW 81 - 92 - 118) '11/2010 >  
2.0 CDTI DPF COSMO S

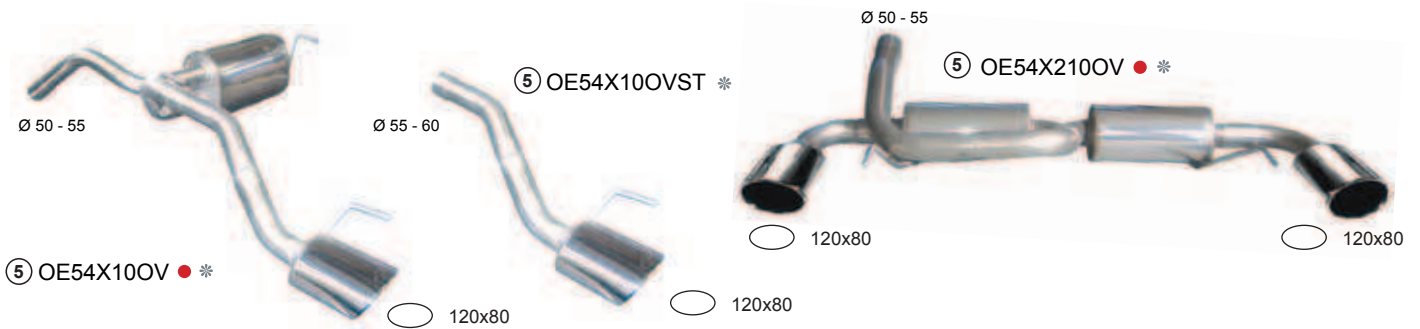

**CORSA** 1.0 12v '97 > 09/'00



**CORSA** 1.0 12v 10/'00 >



**NOTE**  
 Le marmitte alluminizzate hanno tutti i tubi in acciaio INOX 304  
 Alle rohre der alluminierten schalldampfer bestehen aus Edestahl AISI 304  
 All pipes of the alluminized exhausts are made of stainless stell AISI 304

● Omologato / EG-genehmigt - EU-approved  
 \* Acciaio INOX AISI 304 /  
 \* Edelstahl AISI 304 / Stainless stell AISI 304

△ Con modifica paraurti /  
 Änderung der heckschürze / Rear bumper must be cut to fit

<b>CORSA</b> 1.2 8v 3/5 Porte/Doors	03/'93 > 09/'00
1.4 8v 3/5 Porte/Doors - 1.4 GSI 16v 3/5 Porte/Doors	03/'93 > 09/'00
1.6 16v 3/5 Porte/Doors - 1.6 GSI 16v 3/5 Porte/Doors	03/'93 > 09/'00
1.5 TD - 1.7 D	03/'93 > 09/'00
1.2 16v	'97 > 09/'00



① OE32X000  
Collettore / Fächerkrümmer / Manifold 4-2-1  
Per / Für / For mod. 1.4 16v - 1.6 16v



Ø 45 ⑤ OE280080 ●



Ø 45 ④ OE280200 ●



Ø 45 ⑤ OE280082 ●

<b>CORSA</b> 1.2 16v - 1.4 16v - 1.8 16v SPORT 3 Porte	'00 >
--	-------



Ø 45,5 ④ OE450200 ●



Ø 45,5 ⑤ OE450080 ●



Ø 45,5 ⑤ OE450062 ●

○ 70

<b>TIGRA</b> 1.4 - 1.8 16v CABRIO	09/'04 >
-----------------------------------	----------



Ø 4 ④ OE450200 ●



⑤ OE48100V ● Ø 45,5

○ 120x80

- ① Collettore / Fächerkrümmer / Manifold - Down pipe  
 ② Sport metal kat 200 cell  
 ③ Anteriore / Vorshalldämpfer / Front silencer  
 ④ Centrale / Mittelschalldämpfer / Center silencer - pipe  
 ⑤ Posteriore / Endshalldämpfer / Rear silencer - pipe



Sonda Lambda

**TIGRA** 1.4 - 1.6 16v

09/'04 >

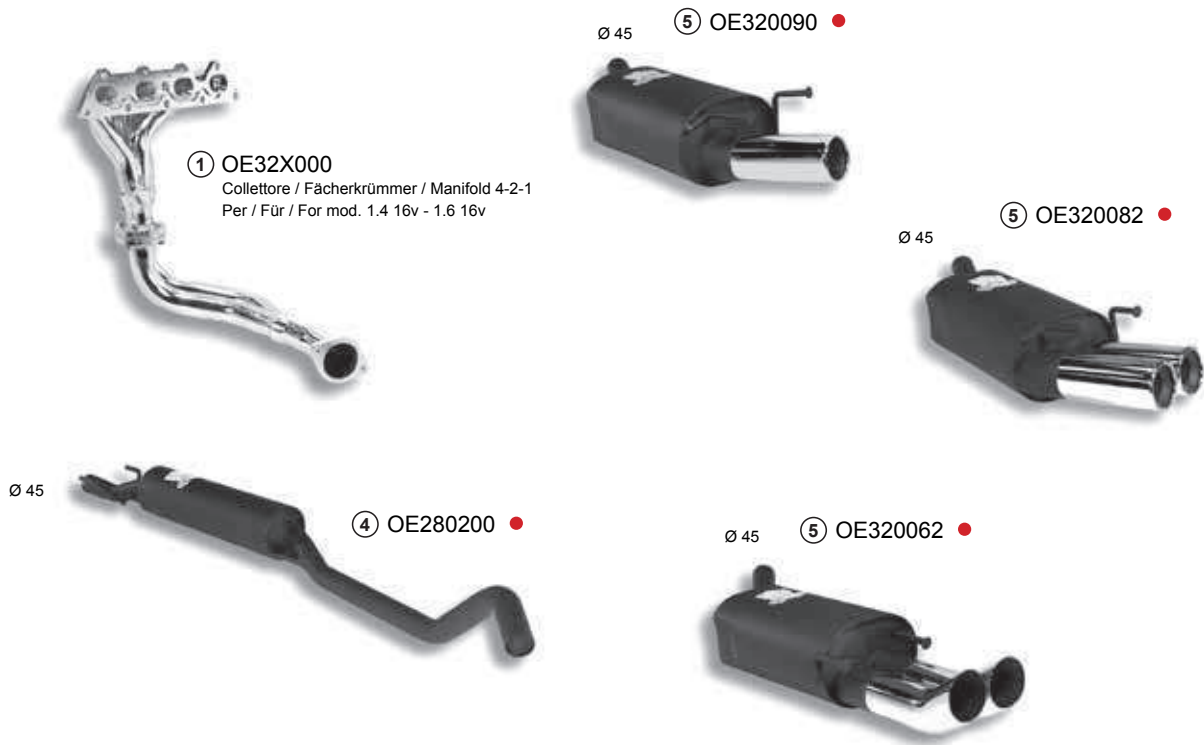

**ANTARA** 2.4 16v - 3.2 V6 - 2.0 CDTI (kW 103 - 167 - 110)

'06 >

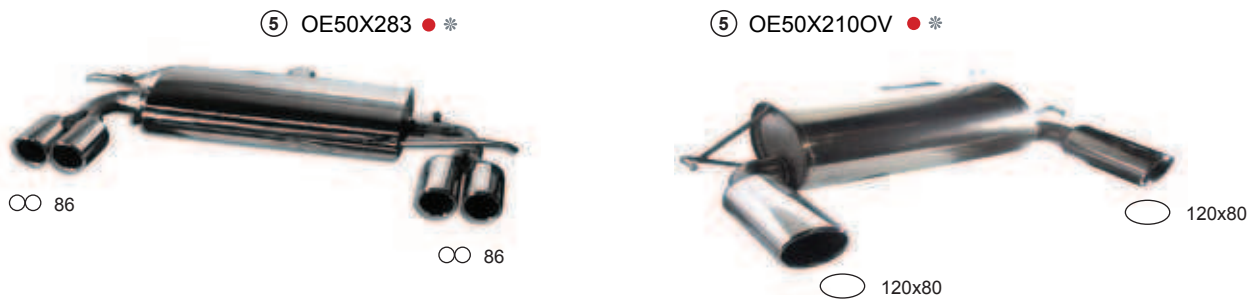

**GT** 2.0 16v Turbo (kW 194)

'07 >

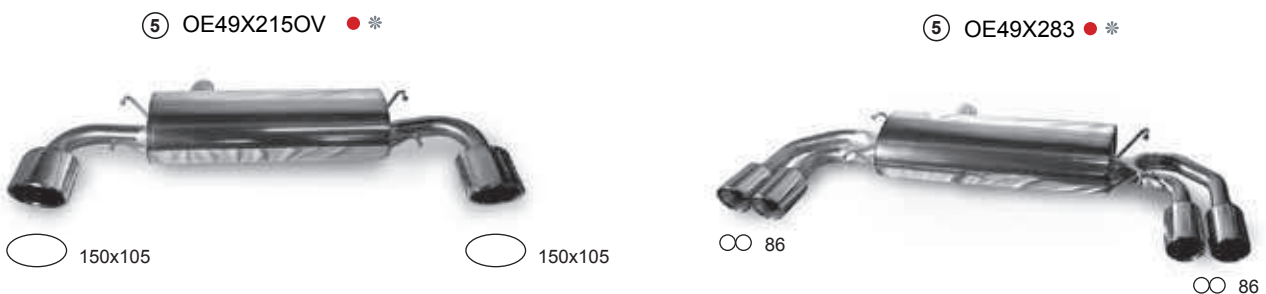

**NOTE**

Le marmite alluminizzate hanno tutti i tubi in acciaio INOX 304  
Alle rohre der alluminierten schalldämpfer bestehen aus Edstahl AISI 304  
All pipes of the alluminized exhausts are made of stainless steel AISI 304

● Omologato / EG-genehmigt - EU-approved

△ Con modifica paraurti /  
Anderung der heckschürze / Rear bumper must be cut to fit

\* Acciaio INOX AISI 304 /  
Edelstahl AISI 304 / Stainless steel AISI 304

## 106 1.1 - 1.4 Cat (kW 44 - 55)

'91 &gt; '00

⑤ PE150070 ●



⑤ PE150072 ●



## 106 1.3i Cat RALLY (kW 74)

'93 &gt;

④ PE180200 ●



⑤ PE150070 ●



⑤ PE150072 ●



## 106 1.4 XSI (kW 72)

10/'91 &gt; '92

① PE140000 \*

Collettore / Fächerkrümmer / Manifold 4-2-1



## 106 1.4 XSI Cat.

10/'91 &gt; '94

① PE14X000 \*

Collettore / Fächerkrümmer / Manifold 4-2-1



④ PE180200 ●



⑤ PE140072 ●



⑤ PE140080 ●



① Collettore / Fächerkrümmer / Manifold - Down pipe

④ Centrale / Mittelschalldämpfer / Center silencer - pipe

② Sport metal kat 200 cell

⑤ Posteriore / Endshalldämpfer / Rear silencer - pipe

③ Anteriore / Vorshalldämpfer / Front silencer



Sonda Lambda

## 106 Cat. 1.4 SPORT

'98 >

1.6 GTI 16v - 1.6 RALLYE 8v / 16v

05/'96 > 05/'98



① C112X000 \*  
Collettore / Fächerkrümmer / Manifold 4-2-1  
Per / Für / For 1.6 16v GTI



④ PE180200 ●



⑤ PE240062 ●

∅ 70

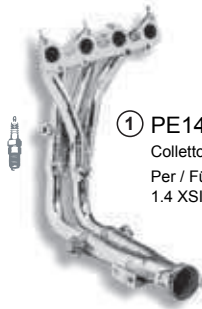

① PE14X000 \*  
Collettore / Fächerkrümmer / Manifold 4-2-1  
Per / Für / For  
1.4 XSI - 1.6 XSI - 1.6 Rallye 8v



⑤ PE240080 ●

∅ 80



⑤ PE240082 ●

∅ 80

## 107 1.0 (kW 50)

'05 >



⑤ C113X082 ● \*

∅ 70x80



⑤ C113X263 ● \*

∅ 60

∅ 60

## 205 RALLY 1.3

08/'89 >



① PE160000 \*  
Collettore / Fächerkrümmer / Manifold 4-2-1

### NOTE

Le marmitte alluminate hanno tutti i tubi in acciaio INOX 304  
Alle rohre der alluminierten schalldämpfer bestehen aus Edestahl AISI 304  
All pipes of the alluminized exhausts are made of stainless steel AISI 304

● Omologato / EG-genehmigt - EU-approved

△ Con modifica paraurti /  
Anderung der heckschürze / Rear bumper must be cut to fit

\* Acciaio INOX AISI 304 /  
Edestahl AISI 304 / Stainless steel AISI 304

## 205 XS (kW 63)

07/'87 &gt; 06/'91



## 205 GTI 1.6 - GTI 1.9

07/'89 &gt; '92



## 205 GTI 1.6 Cat (kW 85)

07/'89 &gt; '92

## GTI 1.9 Cat (kW 96)

07/'89 &gt; 06/'94



## 206 1.1 - 1.4 - 1.6 (kW 44 - 55 - 65)

'98 &gt;



① Collettore / Fächerkrümmer / Manifold - Down pipe

④ Centrale / Mittelschalldämpfer / Center silencer - pipe

② Sport metal kat 200 cell

⑤ Posteriore / Endshalldämpfer / Rear silencer - pipe

③ Anteriore / Vorshalldämpfer / Front silencer



Sonda Lambda

<b>206</b>	1.6 16v - 1.6 16v CC (kW 80)	'98 >
	1.4 XS - 1.6 XS 8v (kW 55 - 65)	'98 >



① PE28X000 \*  
Collettore / Fächerkrümmer / Manifold 4-2-1  
Per / Für / For 1.6 16v



⑤ PE28100V \*



④ PE280200 ●  
Per / Für / For 1.6 16v

④ PE380200 ●  
Per / Für / For 1.6 16v CC



⑤ PE280090 \*

<b>206</b>	2.0 GTI 16v	03/'99 >
	2.0 16v CC	10/'00 >



④ PE270200 ●  
Per / Für / For 2.0 GTI 16v



⑤ PE27100V ●

○ 120x80



⑤ PE270090 ●

○ 90



④ PE320200 ●  
Per / Für / For 2.0 16v CC



⑤ PE27X100V ● \*

○ 120x80



⑤ PE27X090 ● \*

○ 90

### NOTE

Le marmitte alluminate hanno tutti i tubi in acciaio INOX 304  
Alle rohre der alluminierten schalldampfer bestehen aus Edestahl AISI 304  
All pipes of the alluminized exhausts are made of stainless stell AISI 304

● Omologato / EG-genehmigt - EU-approved

△ Con modifica paraurti /  
Anderung der heckschürze / Rear bumper must be cut to fit

\* Acciaio INOX AISI 304 /  
Edestahl AISI 304 / Stainless stell AISI 304

## 206 RC 2.0

05/'03 &gt;



## 206 1.4 HDI

'01 &gt;

## 1.9 D

'01 &gt;



## 206 1.6 HDI

05/'99 &gt;

## 2.0 HDI

05/'99 &gt;



## 207 1.6 (kW 66)

'98 &gt;

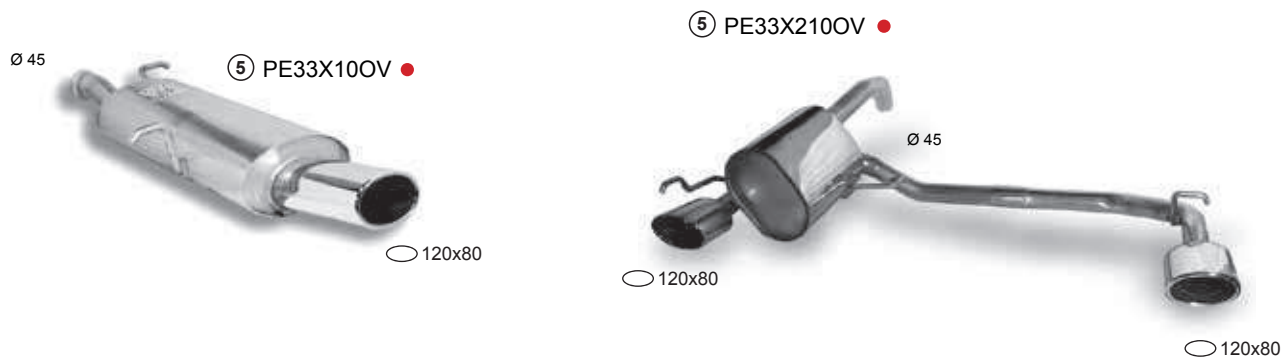

① Collettore / Fächerkrümmer / Manifold - Down pipe

④ Centrale / Mittelschalldämpfer / Center silencer - pipe

② Sport metal kat 200 cell

⑤ Posteriore / Endshaldämpfer / Rear silencer - pipe

③ Anteriore / Vorshaldämpfer / Front silencer



Sonda Lambda

## 207 1.6 16v Turbo (kW 110 - 135)

'98 >

② BM36X100K \*



④ PE31X200 ● \*



⑤ PE31X010 ● \*



∅ 100

## 306 1.1i - 1.4i - 1.6i - 1.8i

02/'93 >

④ PE200200 ● \*



⑤ PE200062 ●



90

⑤ PE200062 ● \*



∅ 70

⑤ PE200035 ● \*



∅ 90x65

## 306 1.6 XS

'97 > '01

④ PE200200 ● \*



⑤ PE250090 ● \*



⑤ PE250035 ● \*



### NOTE

Le marmite alluminizzate hanno tutti i tubi in acciaio INOX 304  
 Alle rohre der alluminierten schalldämpfer bestehen aus Edestahl AISI 304  
 All pipes of the alluminized exhausts are made of stainless steel AISI 304

● Omologato / EG-genehmigt - EU-approved

△ Con modifica paraurti /  
 Änderung der heckschürze / Rear bumper must be cut to fit

\* Acciaio INOX AISI 304 /  
 Edelstahl AISI 304 / Stainless steel AISI 304

306 2.0 8v XSI - 2.0 16v S16

'93 &gt;

2.0 GTI 16v

'97 &gt;



① PE190000 \*  
Collettore / Fächerkrümmer / Manifold 4-2-1  
Esclude il Kat / ohne Kat / Kat replacement  
Per / Für / For mod. 8v



④ PE190200 ●



⑤ PE190090 ●

○ 90



⑤ PE190035 ●

○ 70x80

① Collettore / Fächerkrümmer / Manifold - Down pipe

④ Centrale / Mittelschalldämpfer / Center silencer - pipe

② Sport metal kat 200 cell

⑤ Posteriore / Endshalldämpfer / Rear silencer - pipe

③ Anteriore / Vorshalldämpfer / Front silencer



Sonda Lambda

## 911 2.0 - 2.2 - 2.4 TES

① PS01010S



① PS01010D



⑤ PS010031



## 911 2.7 - CARRERA 3.0

'77 > 12/'83

⑤ PS050031



## 924 5M (kW 92)

'78 > '85

③ PS030100



Ø 50,5

⑤ PS030035



## 924 2.5 Turbo (kW 130)

'79 > '89

## 924 Turbo (kW 162)

'85 >

⑤ PS040035



### NOTE

Le marmitte alluminate hanno tutti i tubi in acciaio INOX 304  
 Alle rohre der alluminierten schalldampfer bestehen aus Edestahl AISI 304  
 All pipes of the alluminized exhausts are made of stainless stell AISI 304

● Omologato / EG-genehmigt - EU-approved

△ Con modifica paraurti /  
 Änderung der heckschürze / Rear bumper must be cut to fit

\* Acciaio INOX AISI 304 /  
 Edestahl AISI 304 / Stainless stell AISI 304

## 964 S

'89 &gt; '93

KIT COMPLETO - KOMPLETTESS KIT - COMPLETE KIT

PS05X010 \*

KIT COMPLETO - KOMPLETTESS KIT - COMPLETE KIT

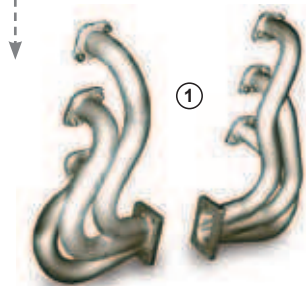

①



④

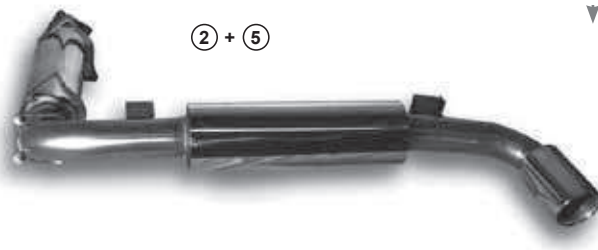

② + ⑤

## 996 3.4i

'96 &gt; '01

CARRERA 4 3.4i

'98 &gt; '01

3.6i - CARRERA 4 3.6i

'02 &gt; '04

3.6i - CARRERA 4S 3.6i

'02 &gt;

⑤ PS07X0PO \*

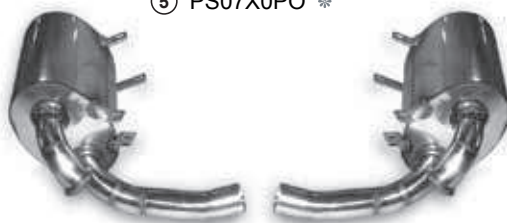

## 997 CARRERA S 3.8i

'04 &gt; '08

CARRERA 3.6i - CARRERA 4S 3.8i

'05 &gt; '08

⑤ PS08X0PO \*



PS08X100V \*



## 997 Turbo

'06 &gt;

Turbo GT2

'08 &gt;

② + ⑤ PS09X0PO \*



① Collettore / Fächerkrümmer / Manifold - Down pipe

④ Centrale / Mittelschalldämpfer / Center silencer - pipe

② Sport metal kat 200 cell

⑤ Posteriore / Endshalldämpfer / Rear silencer - pipe

③ Anteriore / Vorshalldämpfer / Front silencer



Sonda Lambda

## CLIO 1.2 - 1.2i - 1.4 - 1.4i Kat (kW 43 - 57)

05/'90 > '97

④ RE240200 ●  
Per / Für / For 1.2 - 1.4 mod. Cat



⑤ RE190080 ●  
Dal / ab / From '90 al / bis / till '94



⑤ RE310080 ●  
Dal / ab / From '95 al / bis / till '97



## CLIO 1.7

05/'90 > '92

1.8i 16v 3 Porte

01/'91 > '92

1.8i 16v Kat

'91 >

1.8i Baccara RT

07/'91 > 12/'96

1.8i RSi Kat

07/'93 > 12/'96

① RE21X000 \*  
Collettore / Fächerkrümmer / Manifold 4-2-1  
Per / Für / For  
non Kat - without kat version



④ RE210200 ●  
Per / Für / For  
non Kat - without kat version



④ RE250200 ●  
Per / Für / For Kat  
kat version



① RE25X000 \*  
Collettore / Fächerkrümmer / Manifold 4-2-1  
Per / Für / For Kat  
kat version



⑤ RE210080 ●



## CLIO 2.0 ie WILLIAMS

05/'93 > '98

④ RE270200 ●



⑤ RE270080 ●



### NOTE

Le marmite alluminate hanno tutti i tubi in acciaio INOX 304  
Alle rohre der alluminierten schalldampfer bestehen aus Edestahl AISI 304  
All pipes of the alluminized exhausts are made of stainless stell AISI 304

● Omologato / EG-genehmigt - EU-approved

△ Con modifica paraurti /  
Anderung der heckschürze / Rear bumper must be cut to fit

\* Acciaio INOX AISI 304 /  
Edestahl AISI 304 / Stainless stell AISI 304

**CLIO** 1.2 8/16v - 1.4 8/16v - 1.6 8/16v (kW 43 - 55 - 72 - 66 - 79) '98 > '05

**CLIO** 2.0 16v RS (kW 124) '00 > '01

**CLIO** 2.0 RS SPORT II Serie '02 > '04

**CLIO** RS '11 >

④ RE38X200 \*

Foto non disponibile  
Foto nicht verfügbar  
Photo not available

⑤ RE38X002 \*

Foto non disponibile  
Foto nicht verfügbar  
Photo not available

① Collettore / Fächerkrümmer / Manifold - Down pipe

④ Centrale / Mittelschalldämpfer / Center silencer - pipe

② Sport metal kat 200 cell

⑤ Posteriore / Endshalldämpfer / Rear silencer - pipe

③ Anteriore / Vorshalldämpfer / Front silencer



Sonda Lambda

## MEGANE COACH 1.4 Cabrio 16v 1.6 8v / 16v - 2.0 8v / 16v

'95 >



## R5 GT Turbo (kW 88)

'85 > 12/'86

### GT Turbo (kW 88)

01/'87 > '91

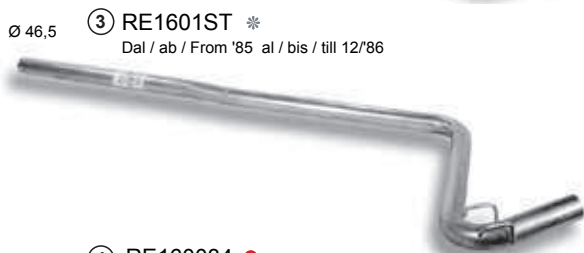

## TWINGO 1.2i Cat (kW 40)

'93 >



### NOTE

Le marmitte alluminizzate hanno tutti i tubi in acciaio INOX 304  
 Alle rohre der alluminierten schalldampfer bestehen aus Edestahl AISI 304  
 All pipes of the alluminized exhausts are made of stainless stell AISI 304

● Omologato / EG-genehmigt - EU-approved

△ Con modifica paraurti /  
 Änderung der heckschürze / Rear bumper must be cut to fit

\* Acciaio INOX AISI 304 /  
 Edestahl AISI 304 / Stainless stell AISI 304

**200** 1.1 - 1.6 '98 >

**214** 8v / 16v '96 >

**216** 8v / 16v



④ RO040200 ●



⑤ RO040035 ●

○ 90x65



⑤ RO040090 ●

○ 90

**200** 1.8 '98 >



④ RO050200 ●



⑤ RO040035 ●

○ 90x65



⑤ RO040090 ●

○ 90

① Collettore / Fächerkrümmer / Manifold - Down pipe

④ Centrale / Mittelschalldämpfer / Center silencer - pipe

② Sport metal kat 200 cell

⑤ Posteriore / Endshalldämpfer / Rear silencer - pipe

③ Anteriore / Vorshalldämpfer / Front silencer



Sonda Lambda

<b>IBIZA</b> 1.4 16v - GT - 1.6i - 1.8i - 1.8i 16v (kW 55 - 74)	09/'96 > '00
1.9 D SDI - 1.9 TDI - 2.0i - 2.0 GTI	09/'96 > '00
1.9 TDI	'01 >

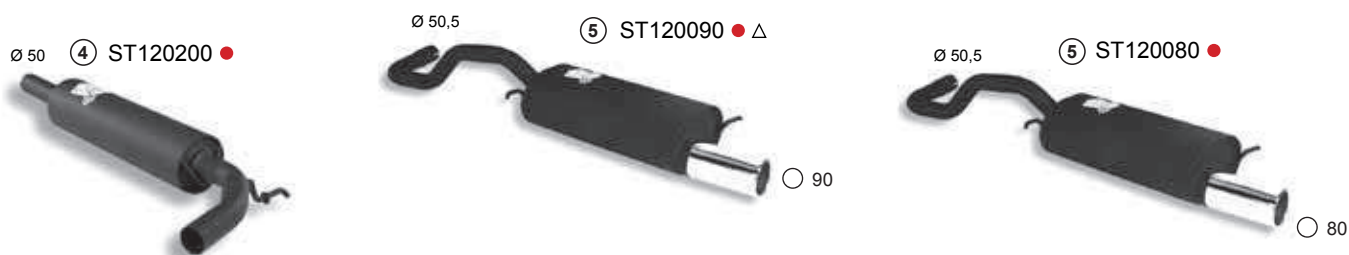

<b>IBIZA</b> 1.4 16v - 1.6 16v	'00 > 12/'01
--------------------------------	--------------



<b>IBIZA</b> 1.8 Turbo - 1.9 TDI	'00 > 12/'01
----------------------------------	--------------

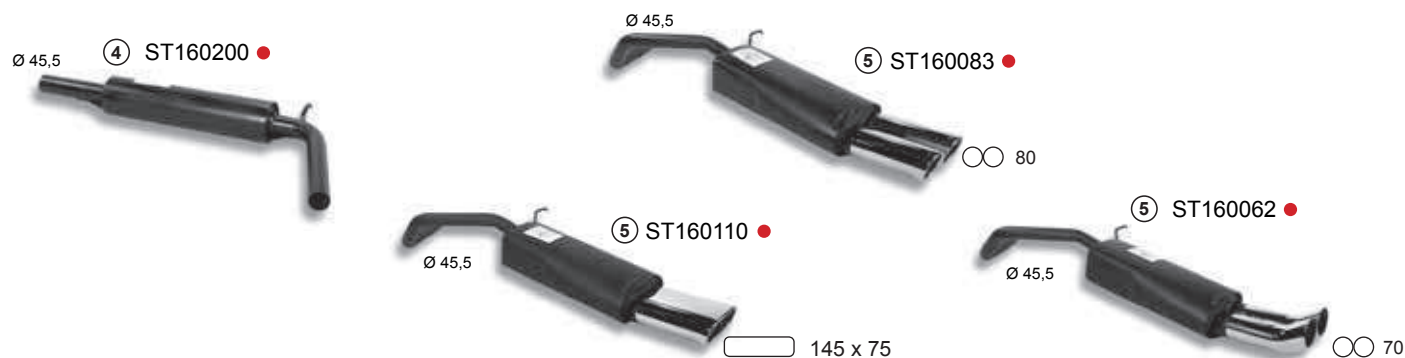

<b>IBIZA</b> 1.4 16v	'02 >
----------------------	-------

**NOTE**

Le marmitte alluminizzate hanno tutti i tubi in acciaio INOX 304  
 Alle rohre der alluminierten schalldämpfer bestehen aus Edestahl AISI 304  
 All pipes of the alluminized exhausts are made of stainless steel AISI 304

● Omologato / EG-genehmigt - EU-approved

Δ Con modifica paraurti /  
 Änderung der heckschürze / Rear bumper must be cut to fit

\* Acciaio INOX AISI 304 /  
 Edestahl AISI 304 / Stainless steel AISI 304

## IBIZA 1.8 Turbo

'03 &gt;



## LEON 1.8 Turbo 20v

'03/'99 &gt;

TDI 90 - 110 - 130 - 150 HP



## LEON 1.8 TSI - 2.0 TSI (kW 118 - 147 - 155)

'05 &gt;



## LEON 2.0 TSI CUPRA / CUPRA R (kW 177 - 195)

11/'06 &gt;

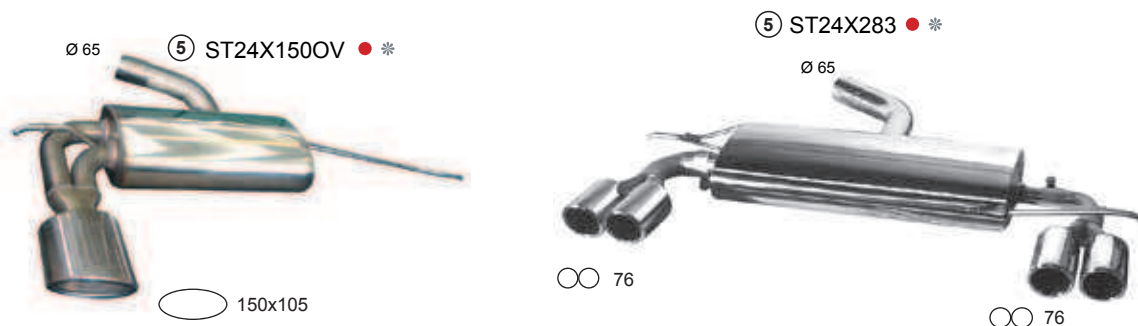

① Collettore / Fächerkrümmer / Manifold - Down pipe

④ Centrale / Mittelschalldämpfer / Center silencer - pipe

② Sport metal kat 200 cell

⑤ Posteriore / Endshalldämpfer / Rear silencer - pipe

③ Anteriore / Vorshalldämpfer / Front silencer



Sonda Lambda

**ALTEA** 1.6 - 2.0 FSI - 1.9 TDI - 2.0 TDI (kW 75 - 77 - 100 - 103)

'04 &gt;

⑤ ST21X083 ● \*

Ø 50 / 55



○○ 76

⑤ ST21X273OV ● \* Δ

Ø 50 / 55



○○ 76

○○ 76

**ALTEA** 1.8 TFSI - 2.0 TFSI (kW 118 - 147)

'04 &gt;

⑤ ST23X083 ● \*

Ø 55 / 65



○○ 76

⑤ ST23X283OV ● \* Δ

Ø 55 / 65



○○ 76

○○ 76

**NOTE**

Le marmite alluminate hanno tutti i tubi in acciaio INOX 304

Alle rohre der alluminierten schalldampfer bestehen aus Edestahl AISI 304

All pipes of the alluminized exhausts are made of stainless stell AISI 304

● Omologato / EG-genehmigt - EU-approved

△ Con modifica paraurti /

Anderung der heckschürze / Rear bumper must be cut to fit

\* Acciaio INOX AISI 304 /  
\* Edelstahl AISI 304 / Stainless stell AISI 304

FABIA 1.4 TSI RS DSG (kW 132)

05/'07

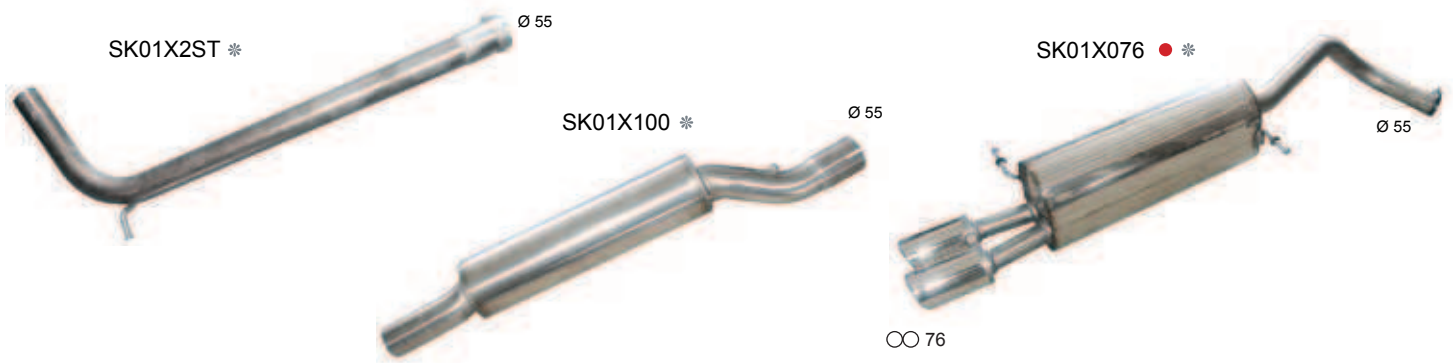

① Collettore / Fächerkrümmer / Manifold - Down pipe

④ Centrale / Mittelschalldämpfer / Center silencer - pipe

② Sport metal kat 200 cell

⑤ Posteriore / Endshalldämpfer / Rear silencer - pipe

③ Anteriore / Vorshalldämpfer / Front silencer



Sonda Lambda

## SMART FORTWO 599cc - EURO 3 (kW 33 - 40 - 45 - 52)

'98 > '04

②+⑤ SM02X082 ● \* Δ



○ 76

SP001



## SMART FORTWO 698cc - EURO 4 (kW 37 - 45 - 55)

'03 >

②+⑤ SM03X082 ● \* Δ



○ 76

SP001



## SMART FORTWO 1.0 Turbo Euro 4 [451] (kW 45 - 52 - 62)

'07 >

②+⑤ SM01X082 ● \* Δ



○ 76

②+⑤ SM01X2110 ● \* Δ



□ 125 x 65

□ 125 x 65

## SMART FORTWO ROADSTER

'03 >

②+⑤ SM04X082 ● \* Δ



○ 76

### NOTE

Le marmite alluminate hanno tutti i tubi in acciaio INOX 304  
 Alle rohre der alluminierten schalldampfer bestehen aus Edestahl AISI 304  
 All pipes of the alluminized exhausts are made of stainless stell AISI 304

● Omologato / EG-genehmigt - EU-approved

Δ Con modifica paraurti /  
 Änderung der heckschürze / Rear bumper must be cut to fit

\* Acciaio INOX AISI 304 /  
 Edelstahl AISI 304 / Stainless stell AISI 304

**IMPREZA** 2.0 AWD - 2.0i Turbo WRX (kW 160 - 195)

'96 &gt; '06

**IMPREZA** 2.0D CONFORT / DYNAMIC - 2.5 AWD (kW 169)

'07 &gt;

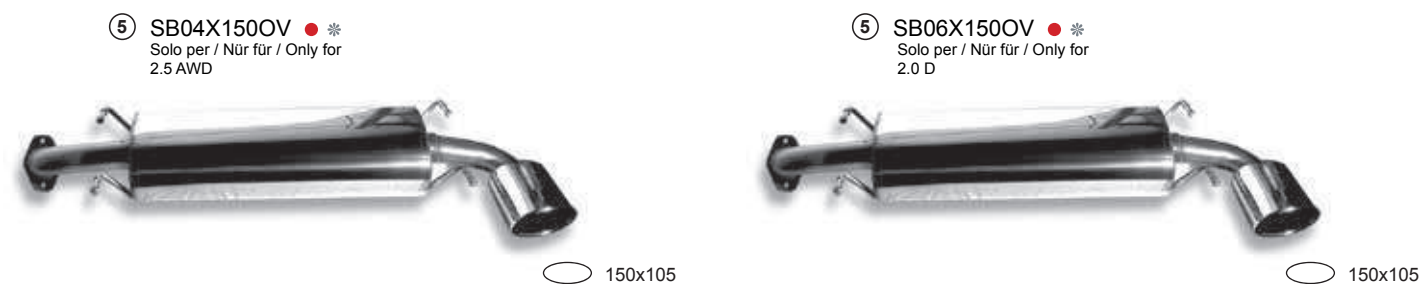
**IMPREZA** 2.5 WRX (kW 221)

'07 &gt;

KIT COMPLETO - KOMPLETTES KIT - COMPLETE KIT Ø 70

**LEGACY** 2.0 AWD 4 doors - StationWagon

'99 &gt; '03

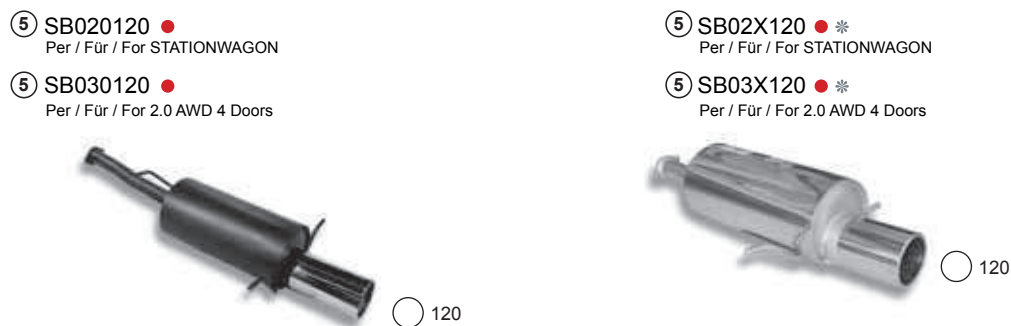

① Collettore / Fächerkrümmer / Manifold - Down pipe

④ Centrale / Mittelschalldämpfer / Center silencer - pipe

② Sport metal kat 200 cell

⑤ Posteriore / Endschalldämpfer / Rear silencer - pipe

③ Anteriore / Vorshalldämpfer / Front silencer



Sonda Lambda

## SUZUKI SWIFT 1.3i 16v GTI (kW 74)

'90 >



## SWIFT 1.6 16v (kW 92)

'05 >



## SUZUKI SJ 410

'82 > '89



## SUZUKI SJ 413

'84 > 07/'92



### NOTE

Le marmitte alluminizzate hanno tutti i tubi in acciaio INOX 304  
Alle rohre der alluminierten schalldampfer bestehen aus Edestahl AISI 304  
All pipes of the alluminized exhausts are made of stainless stell AISI 304

● Omologato / EG-genehmigt - EU-approved

△ Con modifica paraurti /  
Anderung der heckschürze / Rear bumper must be cut to fit

\* Acciaio INOX AISI 304 /  
Edestahl AISI 304 / Stainless stell AISI 304

## SUZUKI SJ 413 MOTORE SWIFT



① SU07X000 \*  
Collettore / Fächerkrümmer / Manifold 4-2-1  
Esclude il Kat / ohne Kat / Kat replacement

## SUZUKI SJ 413 SJ 413 1.3 INIEZIONE



① SU08X000 \*  
Collettore / Fächerkrümmer / Manifold 4-2-1  
Esclude il Kat / ohne Kat / Kat replacement

## SUZUKI SJ 413 SJ 413 MOTORE VITARA 1.6 8v



① SU09X000 \*  
Collettore / Fächerkrümmer / Manifold 4-2-1  
Esclude il Kat / ohne Kat / Kat replacement

## JIMMY 1.3 16v

'98 &gt; '04

① SU06X000 \*  
Collettore / Fächerkrümmer / Manifold 4-1  
Esclude il Kat / ohne Kat / Kat replacement

⑤ SU060031

KIT COMPLETO - KOMPLETTESS KIT - COMPLETE KIT

④ SU06X2ST \*

⑤ SU06X031\*

① Collettore / Fächerkrümmer / Manifold - Down pipe

④ Centrale / Mittelschalldämpfer / Center silencer - pipe

② Sport metal kat 200 cell

⑤ Posteriore / Endschalldämpfer / Rear silencer - pipe

③ Anteriore / Vorshalldämpfer / Front silencer



Sonda Lambda

**SX 4** 1.6 VVT (kW 79 - 88)

'06 >

⑤ SU04X2730V ● \*



**SX 4** 1.6 DDiS - 1.9 DDiS (kW 66 - 88)

'06 >

⑤ FI10X2730V ● \*



**GRAN VITARA** 3 PORTE / DOORS

⑤ SU05X2730V ● \*

Foto non disponibile  
Foto nicht verfügbar  
Photo not available

**NOTE**

Le marmitte alluminate hanno tutti i tubi in acciaio INOX 304  
Alle rohre der alluminierten schalldampfer bestehen aus Edestahl AISI 304  
All pipes of the alluminized exhausts are made of stainless stell AISI 304

● Omologato / EG-genehmigt - EU-approved

△ Con modifica paraurti /  
Anderung der heckschürze / Rear bumper must be cut to fit

\* Acciaio INOX AISI 304 /  
Edelstahl AISI 304 / Stainless stell AISI 304

## YARIS 1.5 VVTI SPORT 3P-5P

'00 &gt; '05

⑤ TO05100V ●



## AYGO 1.0 (kW 50)

'05 &gt;

⑤ C113X082 ●\*

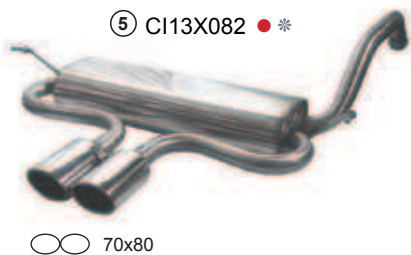

⑤ C113X263 ●\*

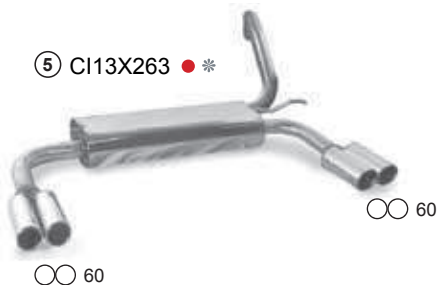

⑤ C113X2110 ●\*



## AURIS

'07 &gt;

IN PREPARAZIONE / IN VORBEREITUNG / AVAIIABLE SOON

① Collettore / Fächerkrümmer / Manifold - Down pipe

④ Centrale / Mittelschalldämpfer / Center silencer - pipe

② Sport metal kat 200 cell

⑤ Posteriore / Endshalldämpfer / Rear silencer - pipe

③ Anteriore / Vorshalldämpfer / Front silencer



Sonda Lambda

## GOLF GTI - GLI 1.6 (kW 81)

GTI 1.8 (kW 82)	'76 > '83
CABRIO 1.6i (kW 81)	01/'79 > 07/'82
CABRIO 1.8 - 1.8 J (kW 66 - 82)	08/'82 > 12/'83
1.6 Turbo DIESEL (kW 51)	05/'82 > 07/'83



## GOLF 1.8 GTI (kW 82)

1.8 GTI (kW 80)	'76 > '83
-----------------	-----------



## GOLF 1.8 GTI 16v (kW 102)

08/'86 > 11/'91



### NOTE

Le marmitte alluminizzate hanno tutti i tubi in acciaio INOX 304  
 Alle rohre der alluminierten schalldämpfer bestehen aus Edestahl AISI 304  
 All pipes of the alluminized exhausts are made of stainless stell AISI 304

● Omologato / EG-genehmigt - EU-approved

△ Con modifica paraurti /  
 Änderung der heckschürze / Rear bumper must be cut to fit

\* Acciaio INOX AISI 304 /  
 Edestahl AISI 304 / Stainless stell AISI 304

**GOLF** 1.8i Cabrio (kW 66 - 82)

'84 > '92

④ VO250200 ●



⑤ VO250080 ●



**GOLF III** GT CABRIO 1.6 (kW 74)

'91 >

1.8i (kW 66)

08/'91 >

2.0 GTI kat. (kW 85)

08/'91 >

① VO12X000 \*  
Collettore / Fächerkrümmer / Manifold 4-2-1  
Solo per / Nür für / Only for 1.8i



⑤ VO260036 ●



④ VO260200 ●



⑤ VO260082 ●



**GOLF III** GTI 2.0i 16v Kat. (kW 110)

12/'91 >

2.8 VR6 Kat.

'91 >

④ VO370200 ●



⑤ VO370082 ●



⑤ VO370036 ●



**GOLF IV** 1.4 16v - 1.6 (kW 55 - 74 - 77 - 92)

'98 >

④ AD140200 ●  
Per / Für / For 1.6 FSI - 1.8 20v



⑤ AD140083 ●



① Collettore / Fächerkrümmer / Manifold - Down pipe

④ Centrale / Mittelschalldämpfer / Center silencer - pipe

② Sport metal kat 200 cell

⑤ Posteriore / Endshalldämpfer / Rear silencer - pipe

③ Anteriore / Vorshalldämpfer / Front silencer



Sonda Lambda

**GOLF IV 1.8 20v** '98 >

**NEW BEETLE 2.0i** 04/'99 >



**GOLF IV 1.8 T GTI (kW 132)** '98 >

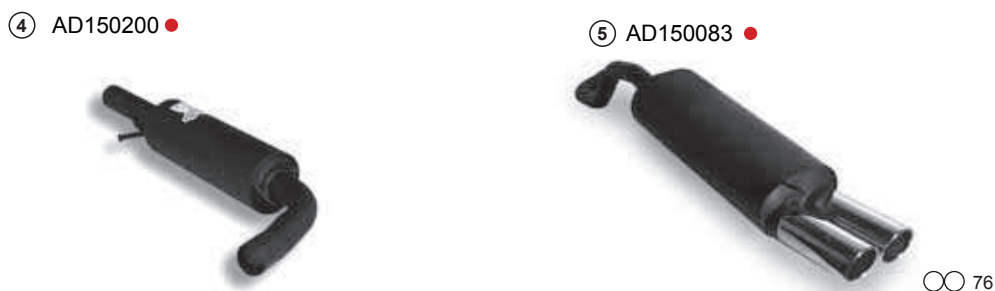

**GOLF IV 1.8 20v Turbo - 1.9 TDI - 2.3 V5** '98 >

**NEW BEETLE 1.8 20v Turbo - 1.9 TDI** 04/'99 >



**GOLF IV 1.9 TDI (kW 66 - 74 - 81 - 85 - 90 - 110)** '98 >



**NOTE**

Le marmitte alluminate hanno tutti i tubi in acciaio INOX 304  
 Alle rohre der alluminierten schalldampfer bestehen aus Edestahl AISI 304  
 All pipes of the alluminized exhausts are made of stainless stell AISI 304

● Omologato / EG-genehmigt - EU-approved

△ Con modifica paraurti /  
 Änderung der heckschürze / Rear bumper must be cut to fit

\* Acciaio INOX AISI 304 /  
 Edestahl AISI 304 / Stainless stell AISI 304

**GOLF V** 1.4 16v - 1.6 16v - 1.6 FSI (kW 59 - 75 - 77 - 90 - 103)

'03 &gt;

⑤ VO52X082 ●\*

Ø 45 - 50



⑤ VO52X282 ●\*

Ø 45 - 50

**GOLF V** 1.4 GTI - 1.4 GTI SPORT (kW 103 - 125)

'03 &gt;

④ VO50X200 ●\*

Ø 55



Ø 55

⑤ VO50X082 ●\*

Ø 76



⑤ VO50X282 ●\*

Ø 55

**GOLF V** 2.0 GTI (kW 147)

'08 &gt;

②+③ VO53X100K \*

Con / mit / with Sport Kat  
200 celle / 200 zellen / 200 cell

Ø 60

④ VO53X200 ●\*



Ø 65

⑤ VO53X082 ●\*



Ø 76

Ø 65

⑤ VO53X282 ●\*



Ø 76

**GOLF V** 1.9 TDI - 2.0 FSI - 2.0 TDI (kW 59 - 75 - 77 - 90 - 103)

'03 &gt;

⑤ VO62X082 ●\*

Ø 55 - 60

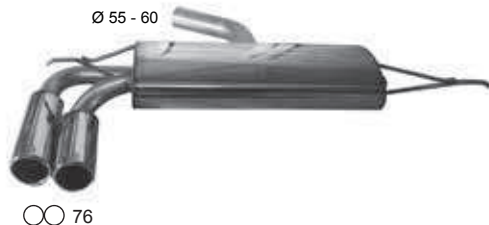

Ø 76

⑤ VO62X282 ●\*

Ø 55 - 60



Ø 76

Ø 76

① Collettore / Fächerkrümmer / Manifold - Down pipe

④ Centrale / Mittelschalldämpfer / Center silencer - pipe

② Sport metal kat 200 cell

⑤ Posteriore / Endshalldämpfer / Rear silencer - pipe

③ Anteriore / Vorshalldämpfer / Front silencer



Sonda Lambda

## GOLF V 2.0 GTD (kW 110)

'03 >

⑤ VO61X082 ● \*



⑤ VO61X282 ● \*



## GOLF VI 1.4 TSI (kW 90 - 118)

'08 >

④ VO58X200 ● \*



⑤ VO54X2730V ● \*



## GOLF VI 2.0 TSI (kW 147 - 155)

'08 >

②+③ VO53X100K \*  
Con / mit / with Sport Kat  
200 celle / 200 zellen / 200 cell



⑤ VO56X210 ● \*

④ VO53X200 ● \*



⑤ VO52X2730V ● \*

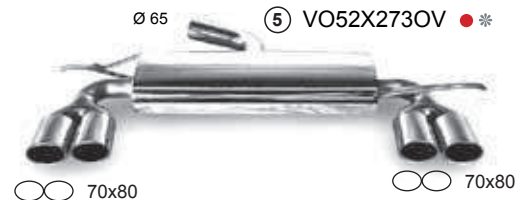

## GOLF VI 1.6 - 2.0 TDI (kW 75 - 81 - 103)

'08 >

⑤ VO55X0760V ● \*



⑤ VO55X2760V ● \*



### NOTE

Le marmitte alluminizzate hanno tutti i tubi in acciaio INOX 304  
Alle rohre der alluminierten schalldampfer bestehen aus Edestahl AISI 304  
All pipes of the alluminized exhausts are made of stainless steel AISI 304

● Omologato / EG-genehmigt - EU-approved

△ Con modifica paraurti /  
Anderung der heckschürze / Rear bumper must be cut to fit

\* Acciaio INOX AISI 304 /  
Edelstahl AISI 304 / Stainless steel AISI 304

## GOLF VI 2.0 TDI (kW 125)

'08 &gt;

⑤ VO63X076OV ● \*



⑤ VO63X276OV ● \*



## GOLF VI R

'08 &gt;

⑤ VO64X210 ● \*

④ AD23X2ST \*

Ø 60

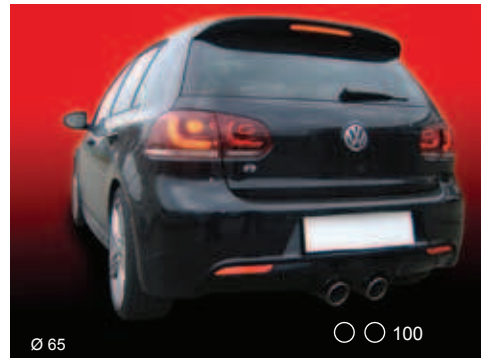

## POLO 1.0i - 1.3i - 1.4i - 1.6i

08/'94 &gt; 11/'01

④ VO400200 ●



Ø 42,5

⑤ VO40100V ●



Ø 42,5

⑤ VO400062 ●



## POLO 1.4i 16v

'96 &gt; 11/'01

④ VO430200 ●



Ø 45,5

⑤ VO43100V ●



Ø 45,5

⑤ VO430062 ●



① Collettore / Fächerkrümmer / Manifold - Down pipe

④ Centrale / Mittelschalldämpfer / Center silencer - pipe

② Sport metal kat 200 cell

⑤ Posteriore / Endshaldämpfer / Rear silencer - pipe

③ Anteriore / Vorshaldämpfer / Front silencer



Sonda Lambda

## POLO III 1.6 16v

01/'99 > 11/'01

1.4 TDI

01/'99 >



## LUPO 1.6 GTI 16v 6M

'00 >



## SCIROCCO 1.4 TSI (kW 118)

'08 >



## SCIROCCO 2.0 TSI (kW 147 - 155)

'08 >

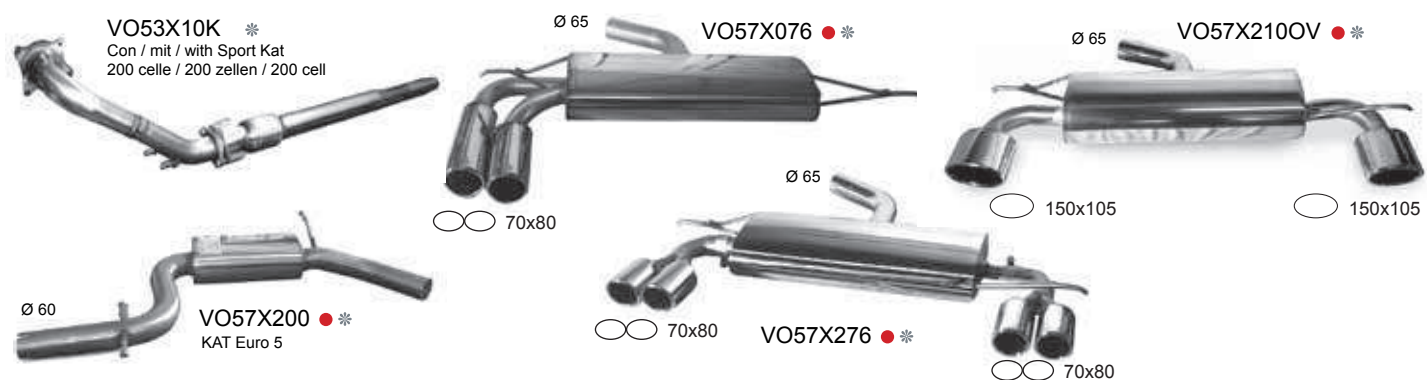

### NOTE

Le marmitte alluminizzate hanno tutti i tubi in acciaio INOX 304  
 Alle rohre der alluminierten schalldampfer bestehen aus Edestahl AISI 304  
 All pipes of the alluminized exhausts are made of stainless stell AISI 304

● Omologato / EG-genehmigt - EU-approved

△ Con modifica paraurti /  
 Änderung der heckschürze / Rear bumper must be cut to fit

\* Acciaio INOX AISI 304 /  
 Edelstahl AISI 304 / Stainless stell AISI 304

**SCIROCCO** R 2.0 TSI (kW 195)

10/'08 &gt;

**TOUAREG** 3.6 V6 FSI - 2.5 TDI - 3.0 TDI (kW 206 - 128 - 165)

'03 &gt;

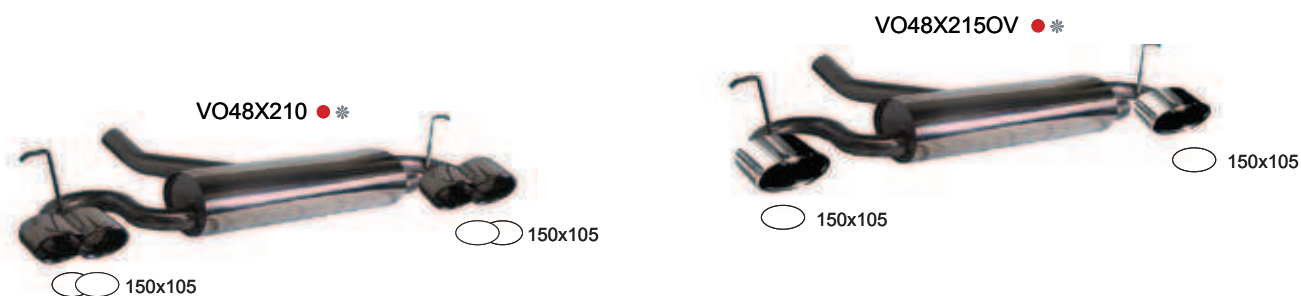
**TOURAN** 1.6 - 1.9 TDI - 2.0 TDI (kW 77 - 103 - 125)

'03 &gt;

**MAGGIOLINO** 1.3 - 1.5 - 1.6 / 1.2 MESSICO

'03 &gt;



- ① Collettore / Fächerkrümmer / Manifold - Down pipe    ④ Centrale / Mittelschalldämpfer / Center silencer - pipe
- ② Sport metal kat 200 cell    ⑤ Posteriore / Endshalldämpfer / Rear silencer - pipe
- ③ Anteriore / Vorshalldämpfer / Front silencer



Sonda Lambda

## 480 TURBO Intercooler Cat.

'90 &gt;

④ VL120200 ●



⑤ VL120080 ●

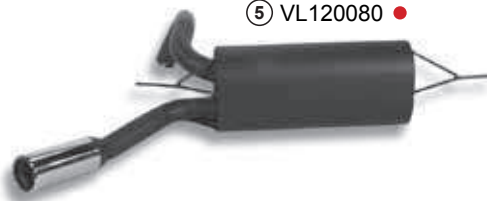

## S 40 / V 40 1.6 16v - 1.8 16v - 2.0 16v

'96 &gt; 11/'04

Ø 47,5

④ VL190200 ●



⑤ VL190083 ●



○ 80

⑤ VL19100V ●



○ 120x80

## S 40 / V 40 T4 Turbo benzina

'00 &gt; 11/'03

Ø 60,5

④ VL200200 ●



⑤ VL20110D ●



○ 145 x 75

⑤ VL200083 ●



○ 80

## C 30 1.6 D

10/2006

⑤ VL01X210ST \*

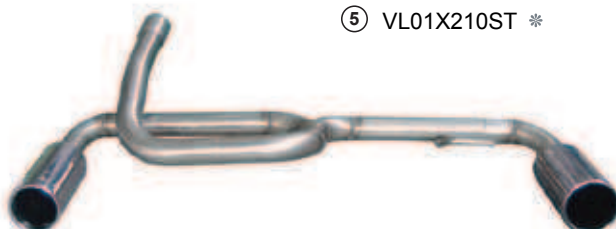

## NOTE

Le marmitte alluminate hanno tutti i tubi in acciaio INOX 304  
 Alle rohre der alluminierten schalldämpfer bestehen aus Edestahl AISI 304  
 All pipes of the alluminized exhausts are made of stainless steel AISI 304

● Omologato / EG-genehmigt - EU-approved

△ Con modifica paraurti /  
 Änderung der heckschürze / Rear bumper must be cut to fit

\* Acciaio INOX AISI 304 /  
 Edestahl AISI 304 / Stainless steel AISI 304

# CONDIZIONI GENERALI DI VENDITA VERKAUFS- UND LIEFERBEDINGUNGEN (AGB) GENERAL SALES CONDITIONS



La KC-CSC S.r.l., di seguito denominata venditrice, si impegna alla fornitura dei prodotti richiesti dal committente, esclusivamente per fax o per posta elettronica alla condizioni sotto riportate da ritenersi parte integrante del contratto. La Venditrice raccomanda a tutti i committenti di specificare chiaramente in ogni ordinazione la quantità, il prezzo unitario ed il numero di codice di riferimento dei prodotti richiesti. La Venditrice deve intendersi sollevata da qualsiasi responsabilità nel caso di erronee indicazioni dei prodotti richiesti, ritenendosi sollevata dall'obbligo della sostituzione, restituzione e rimborso alcuno.

## PERFEZIONAMENTO DEL CONTRATTO

Le vendite effettuate dai mandatarî legittimamente incaricati dalla Venditrice si intendono perfezionate solo dopo l'espressa approvazione della venditrice stessa, la quale potrà sempre riservarsi di rifiutare l'ordine sottoposto secondo il proprio insindacabile giudizio e senza che ciò possa dar luogo a responsabilità pre-contrattuale. Il contratto così perfezionato, nel luogo e alla data dell'accettazione della venditrice, sarà da quest'ultima trasmesso al committente via fax o per mezzo di supporto informatico o telematico.

## DIRITTO DI MODIFICARE I PRODOTTI

La Venditrice si riserva il diritto di apportare in qualsiasi momento e senza preavviso modifiche ai prodotti pubblicati su cataloghi, opuscoli ed altro materiale pubblicitario.

## PREZZI

I prezzi indicati nel listino, da intendersi parte integrante del presente contratto, sono da intendersi franco fabbrica, esclusivamente trasporto, montaggio, IVA ed altre imposte.

## CLAUSOLA PREZZI

La venditrice si riserva di variare in qualsiasi momento il listino prezzi. Il listino allegato al presente atto revoca e sostituisce ogni precedente listino e potrà intendersi vincolante per la Venditrice solo ed esclusivamente per una fornitura di merce, riservandosi la Venditrice il diritto di apportare variazioni al listino per le successive forniture che dovessero essere nuovamente richieste dal Committente.

Die Firma KC-CSC S.r.l. (nachfolgend Anbieter oder Verkäufer genannt) verpflichtet sich zur Lieferung der vom Kunden angefragten Artikel (ausschließlich per Fax oder e-mail) zu den unten aufgeführten Bedingungen.

Der Verkäufer empfiehlt allen Käufern bei jeder Bestellung deutlich die Anzahl, den Stückpreis und die jeweilige Artikelnummer zu erwähnen. Der Verkäufer trägt keinerlei Verantwortung im Falle einer falschen Angabe der angefragten Artikel und es bleibt ihm überlassen, ob er die Ware umtauscht, annimmt oder den Kaufbetrag zurückerstattet. Sollevata dall'obbligo della sostituzione, restituzione e rimborso alcuno.

## VERVOLLSTÄNDIGUNG DES VERTRAGES

Verhandlungen, die durch Dritte für den Anbieter ausgeführt werden, sind nur gültig wenn vom selbigen bestätigt. Der Verkäufer kann die Bestellung jedoch ablehnen, wenn diese seiner Meinung nicht in Ordnung ist. Die abgeänderte Bestellung wird danach dem Kunden vorgelegt. Unter Angabe des Ortes und Datums wird das Einverständnis per fax oder e-mail gesendet.

## VORBEHALT ÄNDERUNGEN VORZUNEHMEN

Der Verkäufer behält sich das Recht vor, nach Erteilung des Auftrages technische Änderungen des Vertragsgegenstandes im Katalog, auf Prospekten oder an anderem Werbematerial vorzunehmen.

## PREISE

Unsere Preise verstehen sich ab Werk, ausschließlich Versandkosten, Montage, MwSt und sonstige Kosten.

## LIEFERBEDINGUNGEN

Bei Sendungen an den Käufer trägt dieser jedes Risiko, auch wenn der Versand durch den Anbieter erfolgt. Insbesondere das Transportrisiko bis zum Eintreffen der Ware beim Verkäufer sowie die gesamten Transportkosten. Derjenige, welche die Sendung annimmt, hat sowohl offensichtliche, wie auch eventuell festgestellte oder sichtbare äußere Beschädigungen (Transportschaden) zu untersuchen und sofort beim Anlieferer zu reklamieren. Sollte eine Überprüfung der Lieferung auf Vollständigkeit und Unversehrtheit eine Differenz ergeben, so hat der Käufer dieses umgehend schriftlich mitzuteilen. Spätere Reklamationen sind ausgeschlossen. Rücksendungen werden nur vorbehaltlich unserer Prüfung angenommen. Aufträge werden zwischen 2 und 15 Werktagen ausgeführt. Für spezielle Aufträge gelten die vorab festgesetzten Lieferbedingungen.

Liefer- und Leistungsverzögerungen aufgrund höherer Gewalt und aufgrund von Ereignissen, die der Anbieter als Lieferant wesentlich erschweren oder unmöglich machen – hierzu gehören insbesondere Streik, Aussperrung, behördliche Anordnungen, usw., auch wenn sie bei Lieferanten vom Anbieter oder deren Unterlieferanten eintreten, hat der Anbieter auch bei verbindlich vereinbarten Fristen und Terminen nicht zu vertreten. Diese berechtigen den Anbieter vielmehr, die Lieferung bzw. Leistung um die Dauer der Behinderung zuzüglich einer angemessenen Anlaufzeit zu schieben oder wegen des noch nicht erfüllten Teiles ganz oder teilweise vom Vertrag zurückzutreten.

C.S.C. S.r.l., hereinafter called the "Seller", shall supply the products requested by the Customer, exclusively by fax or e-mail, under the conditions below, understood to be an integral part of the contract.

The seller advises all customers to clearly specify the quantity, unitary price and the reference code for the desired products in every order. The Seller is exonerated from any responsibility in the event of incorrect indications for requested products and is exonerated from any obligation of replacement, restitution or reimbursement.

## CONTRACT EXECUTION

Sales made by the Seller's legitimately assigned representatives are understood to be executed only after express approval by the Seller, who always reserves the right to refuse an order submitted to him, on his unquestionable decision and without this giving rise to pre-contractual responsibility. Contracts executed in this way, at the place and on the Seller's approval date will be transmitted by this latter to the Customer by fax, I.T. support or data communication means.

## RIGHT TO MODIFY THE PRODUCTS

The seller reserves the right to modify the products published in catalogues, brochures and other advertising material, at any moment and without prior warning.

## PRICES

The prices indicated in the price list, understood to be an integral part of this contract, are understood to be ex-works, excluding transport, assembly, VAT and other taxes.

## DELIVERY TERMS

The goods, sold exclusively ex-factory, travel at the risk and danger of the Customer, even if shipped by the Seller. The customer must check the goods before collection and notify any reserves to the forwarding agent engaged for transportation. Orders for goods already ready in the warehouse will be executed within 2 working days, while those for any other product within 15 working days. For any orders for special parts, not included in the catalogue, the delivery terms will be those agreed upon by the parties.

In any case, delivery terms are always understood to be approximate and possible delays cannot give rise to claims for damage, or contract cancellation or reduction, or termination of the same, even if they are attributable to fortuitous or force majeure circumstances. Cases of force majeure include those dependent on a lack of raw materials, electricity, machinery failures, strikes, fire or other calamities.

# CONDIZIONI GENERALI DI VENDITA VERKAUFS- UND LIEFERBEDINGUNGEN (AGB) GENERAL SALES CONDITIONS



## CERTIFICAZIONI CE

I silenziatori CSC S.r.l. presenti nel catalogo sono completamente adattabili ai ricambi originali, accuratamente testati, approvati ed omologati, e rientrano nei parametri imposti dalle normative vigenti alla data di perfezionamento del contratto. Sono provvisti di certificato di omologazione CE da allegarsi al libretto di circolazione della vettura per essere esibito alle autorità competenti qualora lo richiedessero.

Il suono prodotto dai silenziatori CSC si differenzia da quello prodotto dagli scarichi originali o similari per le diverse caratteristiche interne di composizione, mantiene comunque buoni livelli di rumorosità anche agli alti regimi, rientrando ugualmente nei limiti consentiti dalla normativa vigente all'atto della stipula del contratto.

## PRODUZIONI PERSONALIZZATE

Per la fornitura di scarichi realizzati completamente in acciaio INOX non presenti nel catalogo, di silenziatori con tubi di collegamento e diametri maggiorati e per ogni altra produzione personalizzata, il Committente dovrà preventivamente concordare con la Venditrice il prezzo ed i tempi di consegna, non ritenendosi applicabili a tali forniture le condizioni previste nelle presenti condizioni generali in tema di prezzi e termini di consegna.

## NORMATIVA APPLICABILE E FORO COMPETENTE

Per qualsiasi controversia in ordine alla esecuzione o all'interpretazione del presente contratto si dovrà fare esclusivo riferimento alla normativa italiana, eleggendo quale foro esclusivamente competente il Tribunale di Mantova.



## ALLGEMEINE BETRIEBSERLAUBNIS

Die im Katalog aufgeführten Csc Srl Schalldämpfer können komplett an die Originalteile angepasst werden. Die Artikel werden mit einer Allgemeinen Betriebserlaubnis geliefert, die mit dem Fahrzeugpapieren aufzubewahren und im Falle einer Verkehrskontrolle vorzuweisen ist.

Aufgrund des Innenlebens des Schalldämpfers unterscheidet sich der Geräuschpegel der CSC Schalldämpfer von den Originalschalldämpfern. Ein hochwertiger, guter Sound wird garantiert und es werden dennoch die Einschränkungen der Straßenverkehrsordnung respektiert.

## SPEZIALANFERTIGUNGEN

Für Lieferungen in Edelstahl, die nicht im Katalog aufgeführt sind, Nachschalldämpfer mit Verbindungsrohren, größeren Durchmessern und für weitere spezielle Herstellungen, muss der Anbieter vorab mit dem Käufer den Preis und die Lieferbedingungen festsetzen, da dafür nicht die üblichen gültig sind.

## GERICHTSSTANDÉ

Für diese Geschäftsbedingungen sowie für die gesamten Rechtsbeziehungen zwischen Verkäufer und Käufer gilt das italienische Recht. Zuständiges Gericht ist Mantua.



## C.E. CERTIFICATION

The C.S.C. S.r.l. silencers in the catalogue are completely adaptable to original spare parts, carefully tested, approved and type-approved and fall within the parameters set by the standards in force at the date of contract execution. They are provided with a CE type approval certificate to be enclosed to the car log-book for exhibition to the competent authorities if required. The sound produced by C.S.C. silencers is different to that produced by original or similar exhausts due to the different internal build characteristics; they anyway maintain good noise levels, even at high rpm and satisfy the limits imposed by the regulations in force at the moment of contract stipulation.

## CUSTOMISED PRODUCTIONS

For the supply of exhausts made completely of STAINLESS steel, not present in the catalogue, of silencers with oversized connection pipes and diameters, and for all other customised production, the Customer must agree the price and delivery time beforehand with the Seller as the conditions established by these general conditions for prices and delivery terms are not applicable for these supplies.

## APPLICABLE LAW AND COMPETENT COURT

All disputes concerning the execution or interpretation of this contract must be exclusively disciplined by Italian legislation and the Court of Mantova is elected to be the exclusively competent Court.